

ABP-2000 USER

Fanless Advanced Box PC, 2 LAN, 2 HDMI, 6 COM Onboard
Intel® Atom™ Bay Trail E3845 Quad Core Processor

Manual

Worldwide Technical Support and Product Information

www.vecow.com

Vecow Co., Ltd. Headquarters

12F No 111 Zhongcheng Rd Tucheng Dist New Taipei City 23674 Taiwan R.O.C.

Tel: 886 2 2268 5658

Fax: 886 2 2268 1658

For further support information, refer to the Technical Support and Professional Services appendix. To comment on Vecow Co., Ltd. documentation, refer to the Vecow Co., Ltd. web site at www.vecow.com.

© 2023 Vecow Co., Ltd. All rights reserved.

Record of Revision

Version	Date	Page	Description	Remark
V1.0.0	Jan. 07, 2014	All	Preliminary Release	
V1.0.1	Jan. 20, 2014	p30	GPS Module	
V1.0.2	Feb. 05, 2014	p16-19	Rear Panel DC-IN	
V1.0.3	Jan. 05, 2016	p29	J1 Miscellaneous Pin Header	
V1.0.4	Feb. 22, 2018	p19	Update	
V1.0.5	Mar. 23, 2021	p15	Update	
V1.0.6	Jun. 13, 2023	p9	Update	

Disclaimer

This manual is intended to be used as a practical and informative guide only and is subject to change without prior notice. It does not represent commitment from Vecow Co., Ltd. Vecow shall not be liable for direct, indirect, special, incidental, or consequential damages arising out of the use of the product or documentation, nor for any infringements upon the rights of third parties, which may result from such use.

Declaration of Conformity

FCC This equipment has been tested and found to comply with the limits for a Class A digital device, pursuant to part 15 of the FCC Rules. These limits are designed to provide reasonable protection against harmful interference when the equipment is operated in a commercial environment. This equipment generates, uses, and can radiate radio frequency energy and, if not installed and used in accordance with the instruction manual, may cause harmful interference to radio communications. Operation of this equipment in a residential area is likely to cause harmful interference in which case the user will be required to correct the interference at his own expense.

CE The product(s) described in this manual complies with all applicable European Union (CE) directives if it has a CE marking. For computer systems to remain CE compliant, only CE-compliant parts may be used. Maintaining CE compliance also requires proper cable and cabling techniques.

Copyright and Trademarks

This document contains proprietary information protected by copyright. All rights are reserved. No part of this document may be reproduced by any mechanical, electronic, or other means in any form without prior written permission of the manufacturer. Company/product names mentioned herein are used for identification

Order Information

Part Number	Description
ABP-2845	Fanless Advanced Box PC, 2 Lans, 2 HDMI, 6 COM(2 Isolated COM), 8 GPIO, 5 USB, Terminal Block, Onboard IntelC Atom™ Bay Trail E3845 Quad Core Processor
ABP-2045	Fanless Advanced Box PC, 2 Lans, 2 HDMI, 6 COM, 8 GPIO, 5 USB, DC-Jack, CEC, Onboard Intel® Atom™ Bay Trail E3845 Quad Core Processor
ABP-2015	Fanless Advanced Box PC, 2 Lans, 2 HDMI, 6 COM, 8 GPIO, 5 USB, Terminal Block, Onboard Intel® Atom™ Bay Trail E3815 Processor

Optional Accessories

Part Number	Description
DDR3L8G	Kingston® DDR3L-1600 8G RAM
DDR3L4G	Kingston® DDR3L-1600 4G RAM
M340L-W28M1	Vecow DDR3L 4GB 1333 1066MHz RAM, Micron® Chip, Wide Temperature -40°C ~ +85°C
Onboard GPS Module	u-blox NEO GPS Module with Antenna and Cables Pre-Installed
PWA-60W	60W, 12V 100V AC to 240V AC Power Adapter for DC-Jack
PWA-60WP3	60W, 24V 100V AC to 240V AC Power Adapter for Terminal Block
WiFi module w/ Antenna	WiFi module (Intel N6205) with antenna and cables pre-installed
3G Module w/ Antenna	3G module (Sierra MC8090) with Antenna and cables pre-installed
4G Module w/ Antenna	Sierra MC7710 with Antenna and cables pre-installed

Table of Contents

Disclaimer	iv
Declaration of Conformity	iv
Copyright and Trademarks	iv
FCC	iv
CE	iv
Order Information	v
Optional Accessories	v
General Introduction	1
1.1 Overview	1
1.2 Product Specification	2
1.2.1 Specifications of Vecow ABP-2845	2
1.2.2 Specifications of Vecow ABP-2045	3
1.2.3 Specifications of Vecow ABP-2015	4
1.3 Supported CPU List	5
1.4 Mechanical Dimension	6
Getting to Know Your ABP-2000	9
2.1 Packing List	9
2.2 Front Panel I/O Functions	9
2.2.1 Power, HDD LED Indicator	10
2.2.2 Power Button	10
2.2.3 Rest Tact Switch	11
2.2.4 Ethernet Ports	11
2.2.5 VGA Connector	12
2.2.6 Dual HDMI Connectors	13
2.2.7 Triple USB 3.0 Ports	13
2.2.8 Dual USB 2.0 Ports	14
2.2.9 Eight Bits DIO	14
2.2.10 Audio Connectors	15
2.3 Rear Side External I/O Connectors	16
2.3.1 Serial Ports COM1 and COM2	17
2.3.2 Serial Ports COM3 and COM4	17
2.3.3 Isolated Serial Port COM5 COM6	18
2.3.4 DC-IN 9~28V 5.5Ø DC Jack or Terminal Block	19
2.4 Main Board Expansion Connectors	20
2.4.1 PANEL 1 Miscellaneous Pin Header	22
2.4.2 CN24, CN25, J2 LVDS	23
2.4.3 CN21 SATA II Connector & J1 SATA Power Connector	24
2.4.4 CN23 mSATA Connector	25
2.4.5 CN20, CN22, mini-PCIe Connectors	27
2.4.6 CN29 GPIO	28
2.4.7 Battery	29
2.4.8 GPS Module	30
2.5 Main Board Jumper Setting	31
2.5.1 JP1(A) CMOS Clear Jumper Setting	32
2.5.2 JP1(B) ME Clear Jumper Setting	33
2.5.3 JP2 LVDS Backlight Power Selection	34

System Setup	35
3.1 Install DDR3 / DDR3L SODIMM Modules	35
3.2 Install SSD HDD	36
3.3 Mount Your ABP-2000	38
BIOS and Driver	40
4.1 BIOS Settings	40
4.1.1 Main Menu	40
4.2 Advanced Function	41
4.2.1 ACPI Setting	41
4.2.2 Serial Port 1 Configuration	42
4.2.3 Serial Port 2 Configuration	43
4.2.4 Serial Port 3 Configuration	44
4.2.5 Serial Port 4 Configuration	45
4.2.6 Serial Port 5 Configuration	46
4.2.7 Serial Port 6 Configuration	47
4.2.8 PPM Configuration	48
4.2.9 CPU Configuration	48
4.2.10 IDE Configuration	49
4.3 Chipset Function	50
4.3.1 Display Configuration	50
4.3.2 Power Loss Configuration	51
4.4 Boot Function	52
4.4.1 Change Boot Configuration	52
4.5 Save & Exit	53
4.5.1 1.5.1. Reload Default BIOS Value	53
Appendix A : GPIO & WDT	54

1

General Introduction

1.1 Overview

ABP-2000 series are equipped with Intel® Quad-Core Atom™ E3800 (formerly codenamed Bay Trail) processor family (1.91GHz) and DDR3L single channel 8GB ram, 2 HDMI display, 2 RS-232, 2 RS-232/422/485, 2 isolated RS-232/422/485, 2 GbE LANs, one 2.5" SATA 3Gp/s SSD/HDD tray, 3 USB 3.0 ports, 2 USB 2.0, and 2 miniPCI-express.

ABP-2000 series is in fanless smart form factor and capable of operating under wide temperatures from -25°C to +70°C for harsh environments. With cutting-edge graphics and computing technologies, ABP-2000 series enable to present high quality resolution 3D display as low power consumption.

Design with 6 COM to satisfy various applications' control and connection requirements, ABP-2000 series still keep fanless and wide operation temperature plus with EN50155 standard and cable-less arrangement for industrial harsh environment.

ABP-2000 series is ideal for information display in harsh environment, automation networking communication, IOT (Internet of Things), In-Vehicle Infotainment (IVI) systems, and M2M (Machine to Machine) applications.

1.2 Product Specification

1.2.1 Specifications of Vecow ABP-2845

System	
Processor	Intel® Atom™ Quad Core Valleyview (Bay Trail) Processor (E3845 1.91GHz)
Chipset	Valleyview SoC
Memory	1 DDR3L 1600 SODIMM, Max. 8Gb
Video	1 DB 15 VGA 2 HDMI 1.4 Optional BOM: LVDS 48bit
Audio	1 Mic-In, 1 Line-Out
Software Support	Windows 8, Windows 7, WES7
I/O Ports	
Serial Interface	6 COM Ports; 2 RS-232, 4 RS-232/422/485 2 Isolated RS-232/422/485
LAN	2 Intel® GbE WG82574L
USB	3 USB 3.0, 2 USB 2.0
GPIO	8 GPIO
Mini PCIe Slot	miniPCIe Socket (PCIe+USB +SIM card socket) miniPCIe Socket (PCIe+USB) mSATA Socket 3 Pre-Cast Holes for Antenna
Power Supply	
Power Input	Terminal Block ATX: 2-Pin Remote Power On/Off Switch Optional BOM: On-Board Power Input for PPC
Power Output	On-Board 12V
Storage	
SATA HDD	1 SATA II Ports at 3.0Gb/s
mSATA	1 miniPCIe(full size) Supports mSATA
Other	
Watchdog Timer	Reset: 1 to 255 sec / min Per Step
GPS	On-Board GPS Module (Optional)
Mechanical	
Dimension (W x L x H)	257mm x 141mm x 48mm (10.1" x 5.6" x 1.9")
Weight	2.1Kg (4.6 lb)
Mounting	Wall-mount by Mounting Bracket
Design	Compact
Environmental	
Operating Temperature	-25°C to 70°C (-13°F to 157°F)
Storage Temperature	-40°C to 85°C (-40°F to 185°F)
Humidity	10% to 95% Humidity, Non-condensing
Shock	Operating, 50 Gms, Half-Sine 11 ms Duration (w / SSD, According to IEC60068-2-27)
Vibration	Random: 5 Grms @ 5-500Hz according to IEC68-2-64 Sinusoidal: 5 Grms @5-500 Hz according to IEC68-2-64
EMC	CE, FCC, EN50155, RoHS

1.2.2 Specifications of Vecow ABP-2045

System	
Processor	Intel® Atom™ Quad Core Valleyview (Bay Trail) Processor (E3845 1.91GHz)
Chipset	Valleyview SoC
Memory	1 DDR3L 1600 SODIMM, Max. 8Gb
Video	1 DB 15 VGA 2 HDMI 1.4 with CEC Control Optional BOM: LVDS 48bit
Audio	1 Mic-In, 1 Line-Out
Software Support	Windows 8, Windows 7, WES7
I/O Ports	
Serial Interface	6 COM Ports; 2 RS-232, 4 RS-232/422/485
LAN	2 Intel® GbE WG82574L
USB	3 USB 3.0, 2 USB 2.0
GPIO	8 GPIO
Mini PCIe Slot	miniPCIe Socket (PCIe+USB +SIM card socket) miniPCIe Socket (PCIe+USB) mSATA Socket 3 Pre-Cast Holes for Antenna
Power Supply	
Power Input	DC-IN 9~28V ATX: 2-Pin Remote Power On/Off Switch Optional BOM: On-Board Power Input for PPC
Power Output	On-Board 12V
Storage	
SATA HDD	1 SATA II Ports at 3.0Gb/s
mSATA	1 miniPCIe(full size) Supports mSATA
Other	
Watchdog Timer	Reset: 1 to 255 sec / min Per Step
GPS	On-Board GPS Module (Optional)
Mechanical	
Dimension (W x L x H)	257mm x 141mm x 48mm (10.1" x 5.6" x 1.9")
Weight	2.1Kg (4.6 lb)
Mounting	Wall-mount by Mounting Bracket
Design	Compact
Environmental	
Operating Temperature	-25°C to 70°C (-13°F to 157°F)
Storage Temperature	-40°C to 85°C (-40°F to 185°F)
Humidity	10% to 95% Humidity, Non-condensing
Shock	Operating, 50 Gms, Half-Sine 11 ms Duration (w / SSD, According to IEC60068-2-27)
Vibration	Random: 5 Grms @ 5-500Hz according to IEC68-2-64 Sinusoidal: 5 Grms @5-500 Hz according to IEC68-2-64
EMC	CE, FCC, EN50155, RoHS

1.2.3 Specifications of Vecow ABP-2015

System	
Processor	Intel® Atom™ Valleyview (Bay Trail) Processor (E3815 1.46GHz)
Chipset	Valleyview SoC
Memory	1 DDR3L 1600 SODIMM, Max. 8Gb
Video	1 DB 15 VGA 2 HDMI 1.4 Optional BOM: LVDS 48bit
Audio	1 Mic-In, 1 Line-Out
Software Support	Windows 8, Windows 7, WES7
I/O Ports	
Serial Interface	6 COM Ports; 2 RS-232, 4 RS-232/422/485
LAN	2 Intel® GbE WG82574L
USB	3 USB 3.0, 2 USB 2.0
GPIO	8 GPIO
Mini PCIe Slot	miniPCIe Socket (PCIe+USB +SIM card socket) miniPCIe Socket (PCIe+USB) mSATA Socket 3 Pre-Cast Holes for Antenna
Power Supply	
Power Input	Terminal Block ATX: 2-Pin Remote Power On/Off Switch Optional BOM: On-Board Power Input for PPC
Power Output	On-Board 12V
Storage	
SATA HDD	1 SATA II Ports at 3.0Gb/s
mSATA	1 miniPCIe(full size) Supports mSATA
Other	
Watchdog Timer	Reset: 1 to 255 sec / min Per Step
GPS	On-Board GPS Module (Optional)
Mechanical	
Dimension (W x L x H)	257mm x 141mm x 48mm (10.1" x 5.6" x 1.9")
Weight	2.1Kg (4.6 lb)
Mounting	Wall-mount by Mounting Bracket
Design	Compact
Environmental	
Operating Temperature	-25°C to 70°C (-13°F to 157°F)
Storage Temperature	-40°C to 85°C (-40°F to 185°F)
Humidity	10% to 95% Humidity, Non-condensing
Shock	Operating, 50 Gms, Half-Sine 11 ms Duration (w / SSD, According to IEC60068-2-27)
Vibration	Random: 5 Grms @ 5-500Hz according to IEC68-2-64 Sinusoidal: 5 Grms @5-500 Hz according to IEC68-2-64
EMC	CE, FCC, EN50155, RoHS

1.3 Supported CPU List

Vecow ABP-2000 series is based on Intel® Atom™ Bay Trail platform and accepts the following Bay Trail-I Family processors.

E3845 and E3815 are selected in ABP-2000 series standard models, and the rest is available upon project-base.

Processor No.	Core Count	CPU Freq (GHz)	Gfx Freq (MHz) Nominal/Turbo	TDP
E3845	4C	1.91GHz	542/792	10W
E3827	2C	1.75GHz	542/792	8W
E3826	2C	1.46GHz	533/667	7W
E3825	2C	1.33 GHz	533 (No Turbo)	6W
E3815	1C	1.46 GHz	400 (No Turbo)	5W

1.4 Mechanical Dimension

Figure 1.1 ABP-2845

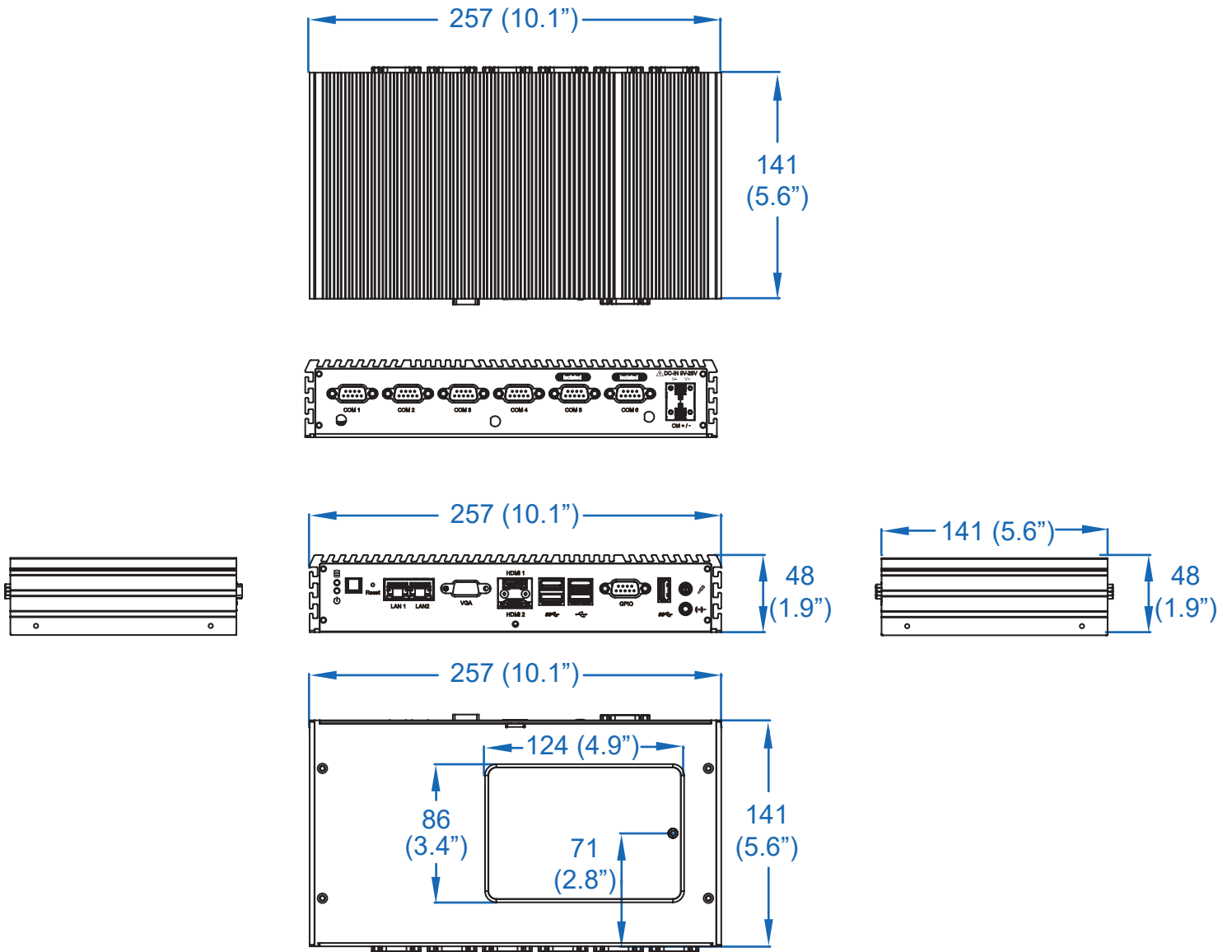

Figure 1.2 ABP-2045

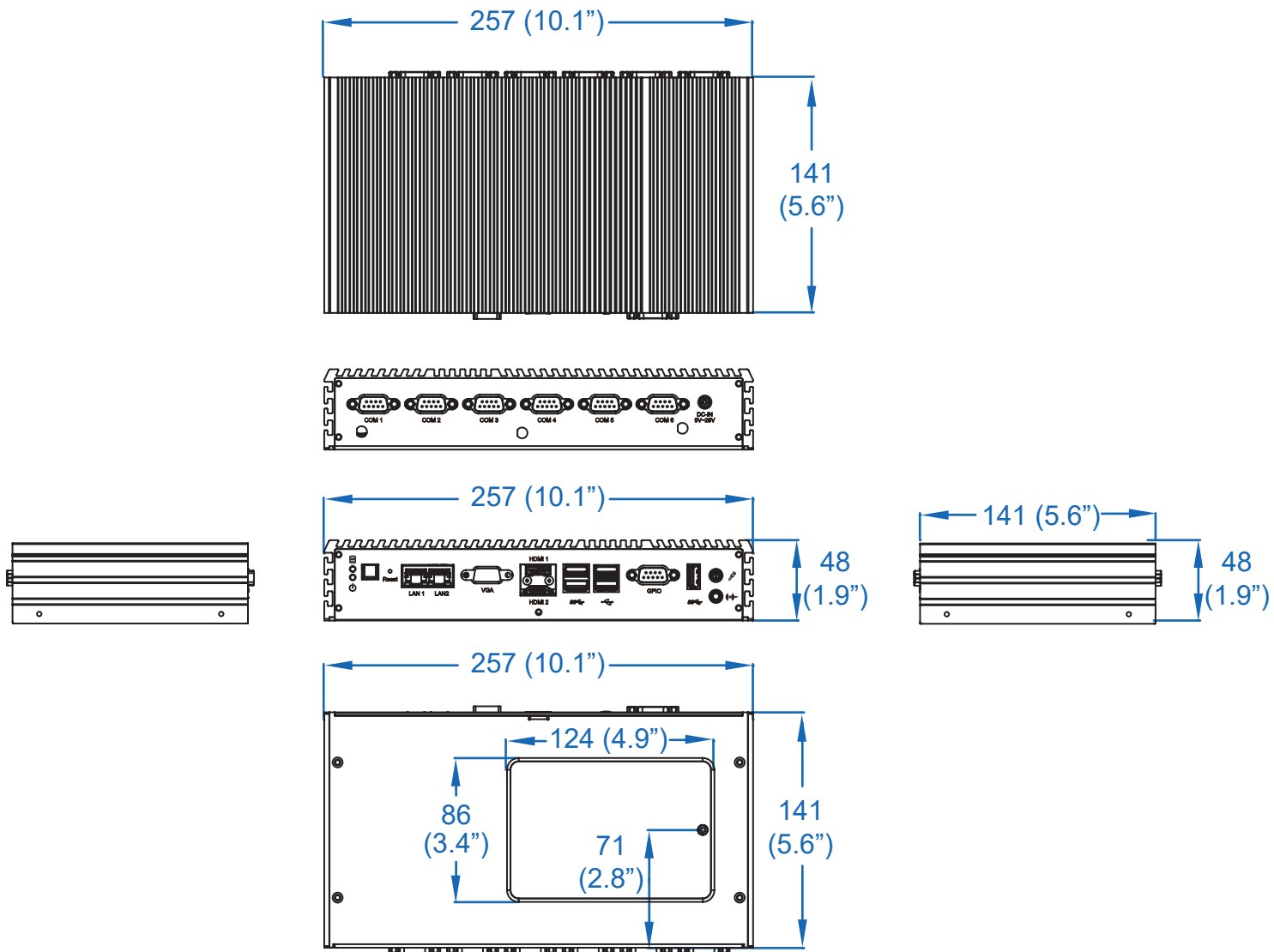
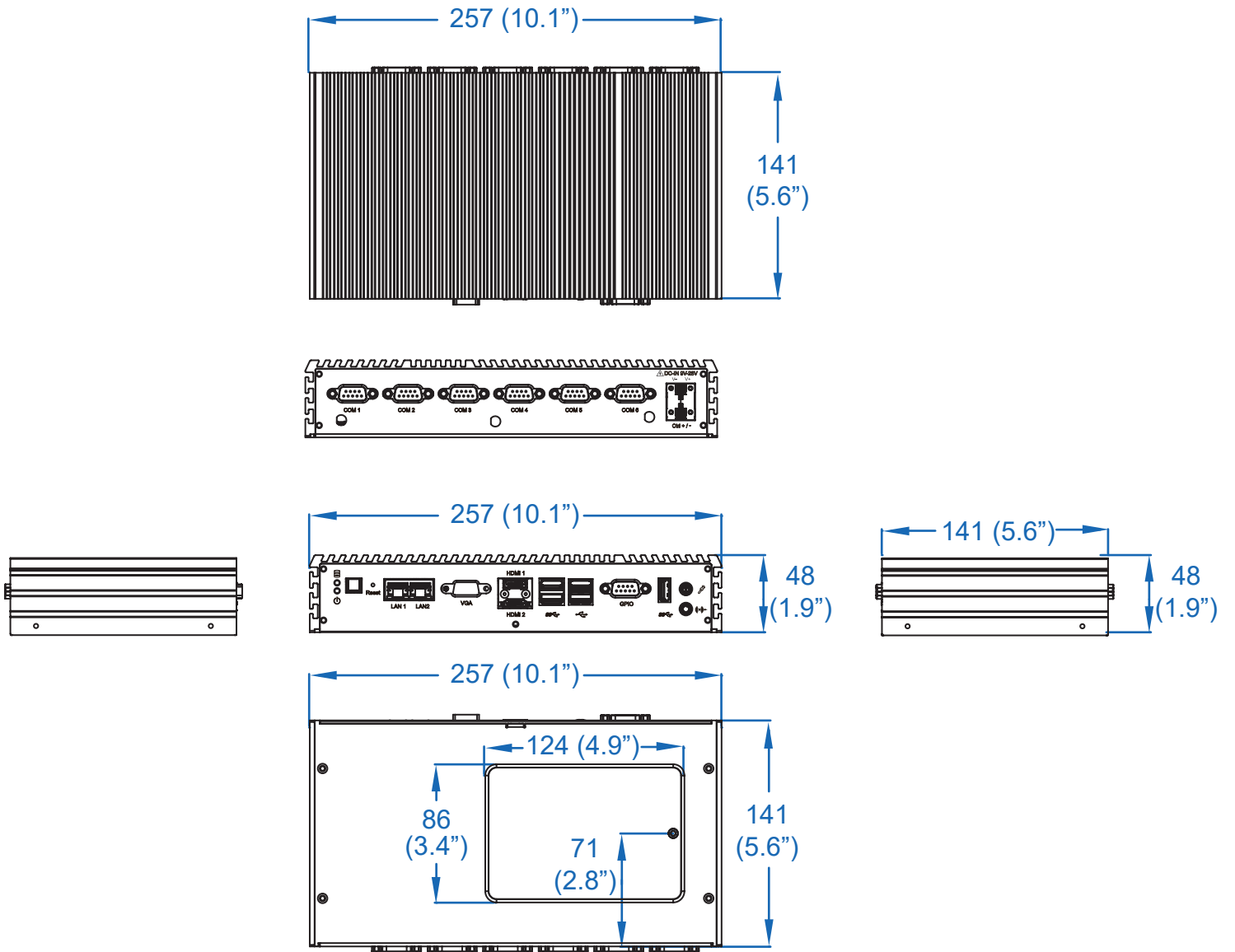

Figure 1.3 ABP-2015



2

Getting to Know Your ABP-2000

2.1 Packing List

Item	Description	Qty
1	ABP-2000 series fanless controller (According to the configuration you order, the system may pre-install SSD/HDD and DDR3L SO-DIMM. Please verify these items if necessary.)	1
2	Accessory box, which contains <ul style="list-style-type: none">• Wall-mounting bracket• M4 screws for wall-mounting bracket• 2-pin pluggable terminal block (ABP-2845 and ABP-2015)	2 4 2

2.2 Front Panel I/O Functions

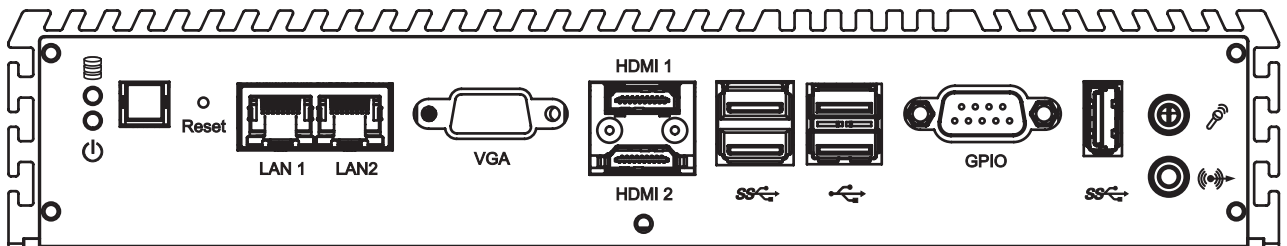

On ABP-2000 series, all I/O connectors are located on front panel and rear panel. Most general computer connectors (i.e. audio, USB, HDMI, VGA and etc.) are placed on the front panel.

2.2.1 Power, HDD LED Indicator

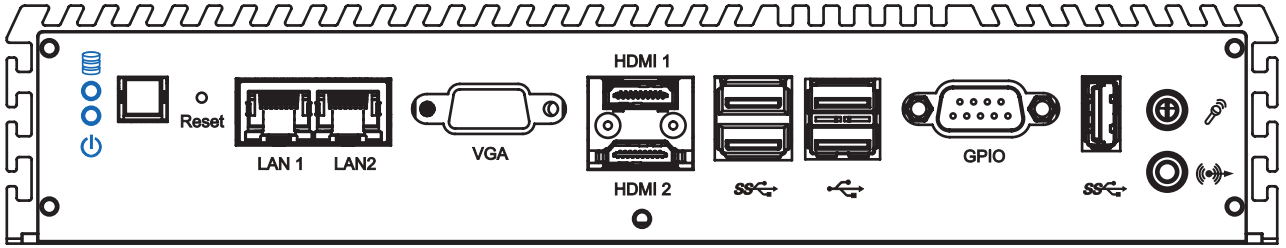

Yellow-HDD LED: A hard disk / CFast LED. If the LED is on, it indicates that the system's storage is functional. If it is off, it indicates that the system's storage is not functional. If it is flashing, it indicates data access activities.

Green-Power LED: If the LED is solid green, it indicates that the system is powered on.

2.2.2 Power Button

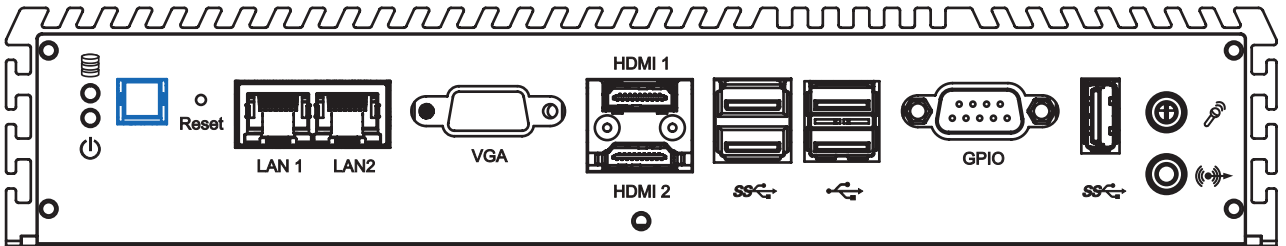

The power button is a non-latched switch with dual color LED (Blue/Orange) for indication S0, S3 and S5 status. Power button dual-color LED indicator:

Status	LED Display	System Situation
S0	Solid Blue	System working
S3, S5	Solid Orange	Suspend to RAM, System off with standby power

To turn on the ABP-2000 series, press the power button and the blue LED is lighted up. To turn off the ABP-2000 series, you can either issue a shutdown command in OS, or just simply press the power button.

In case of system halts, you can press and hold the power button for 4 seconds to compulsorily shut down the system. Please note that a 4 seconds interval is kept by the system between two on/off operations (i.e. once turning off the system, you shall wait for 4 seconds to initiate another power-on operation).

2.2.3 Rest Tact Switch

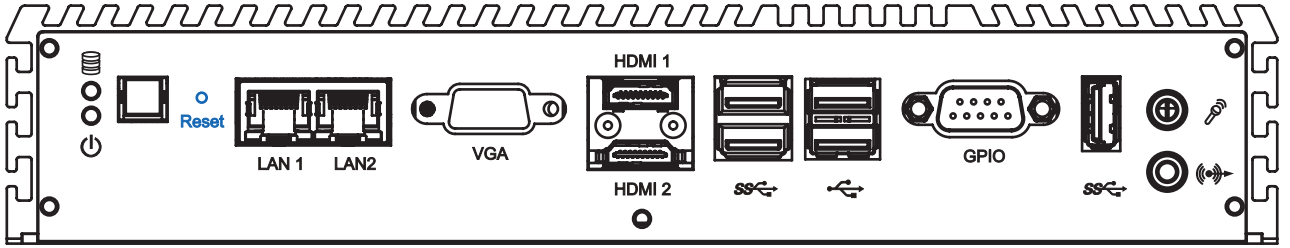

It is a hardware reset switch. Use this switch to reset the system without turning off the power. Momentarily pressing the switch will activate a reset.

2.2.4 Ethernet Ports

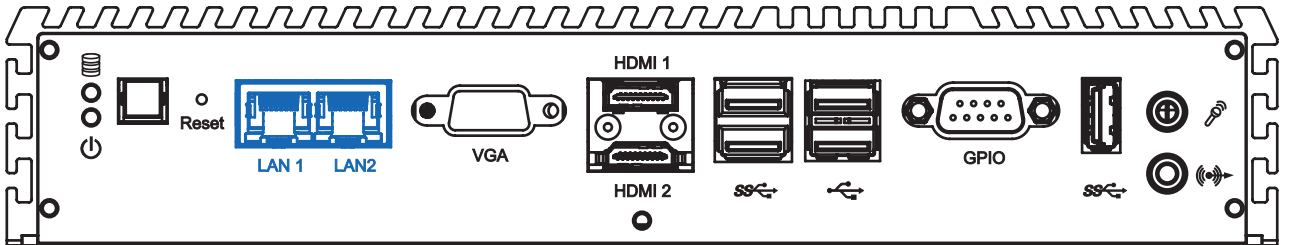

The 10/100/1000 Mbps Ethernet LAN ports 1 and 2 use 8-pin RJ-45 connectors. LAN1 and LAN2 are equipped with Intel® 82574L controllers.

Using suitable RJ-45 cable, you can connect ABP-2000 series system to a computer, or to any other piece of equipment that has an Ethernet connection, for example, a hub or a switch. Moreover, both of them have Wake-on-LAN and pre-boot Execution Environment capabilities.

The following diagram shows the pinouts for LAN1 and LAN2 ports.

Pin No.	10 / 100 Mbps	1000 Mbps
1	E_TX+	MDI0_P
2	E_TX-	MDI0_N
3	E_RX+	MDI1_P
4	----	MDI2_P
5	-----	MDI2_N
6	E_RX-	MDI1_N
7	-----	MDI3_P
8	-----	MDI3_N

The Ethernet ports use standard RJ-45 jack connectors with LED indicators on the front side to show Active/Link status and Speed status. The LED indicators on

the right bottom corners glow a solid green color when the cable is properly connected to a 100 Mbps Ethernet network. The LED indicator on the left bottom corner will flash on and off when Ethernet packets are being transmitted or received.

The LED indicators on the right bottom corners glow a solid orange color when the cable is properly connected to a 1000 Mbps Ethernet network. The LED indicator on the left bottom corner will flash on and off when Ethernet packets are being transmitted or received.

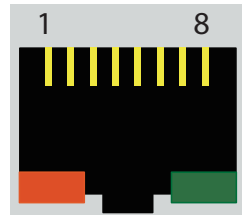

Location	10 Mbps	100 Mbps	1000 Mbps
Right Bottom LED	off	Solid Green	Solid Orange
Left Bottom LED	Flash Yellow	Flash Yellow	Flash Yellow

2.2.5 VGA Connector

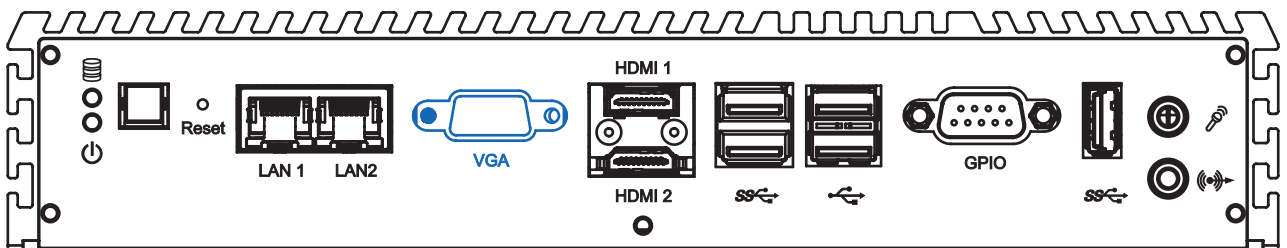

The ABP-2000 series comes with a DB15 female connector on the front panel to connect a VGA monitor. To ensure that the monitor image remains clear, be sure to tighten the monitor cable after connecting it to the ABP-2000. The VGA output mode supports up to **2560x1600** resolutions. The pin assignments of the VGA connector are shown below.

Pin No.	Description
1	Red Color Signal
2	Green Color Signal
3	Blue Color Signal
4	NC
5	Ground
6	VGA Detect

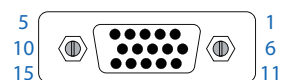

Pin No.	Description
7	Ground
8	Ground
9	VCC
10	Ground
11	NC
12	DDC-DATA
13	H-Sync.
14	V-Sync.
15	DDC-CLK

2.2.6 Dual HDMI Connectors

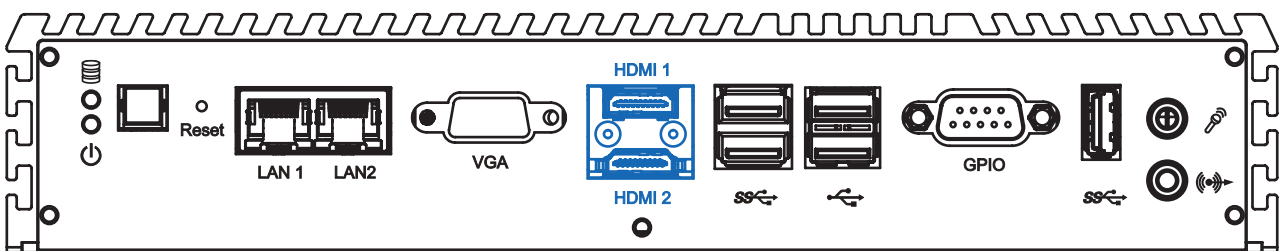

Each HDMI output mode supports up to **2560x1600** resolutions. The HDMI mode is automatically selected according to the display device connected.

2.2.7 Triple USB 3.0 Ports

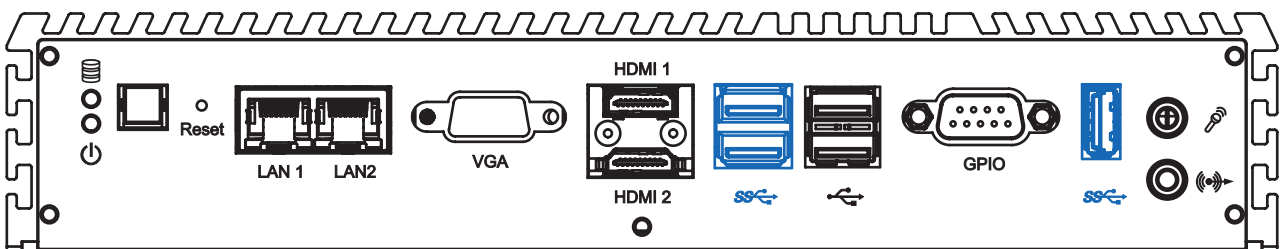

The ABP-2000 series comes with 3 USB 3.0 hosts on the front panel. These USB 3.0 ports allow data transfers up to 5 Gb/s. The controller supports SuperSpeed (SS), high-speed (HS), full-speed (FS) and low-speed (LS) traffic on the bus.

2.2.8 Dual USB 2.0 Ports

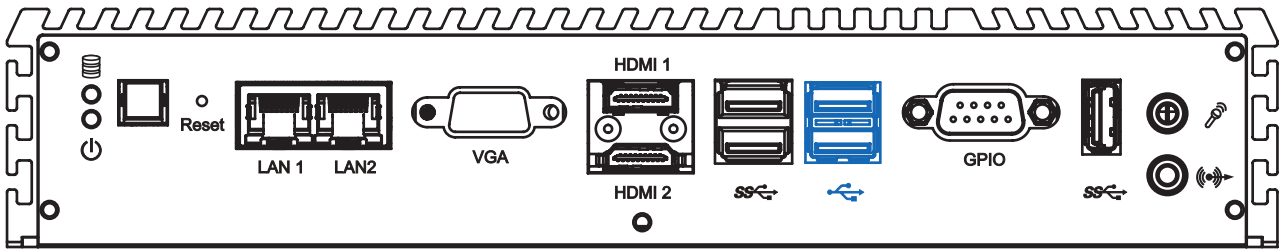

The ABP-2000 series comes with 2 USB 2.0 hosts on the front panel. The USB interface supports Plug and Play, which enables you to connect or disconnect a device whenever you want, without turning off the system.

The hosts can be used for an external flash disk or hard drive for storing large amounts of data. You can also use these USB hosts to connect to a keyboard or a mouse. The following diagram shows the pinouts for USB ports.

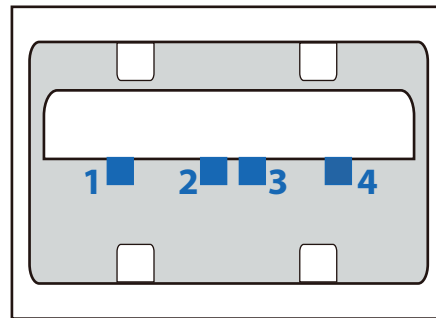

Pin Number	1	2	3	4
USB1	+5V	USB1-	USB1+	GND
USB2	+5V	USB2-	USB2+	GND

2.2.9 Eight Bits DIO

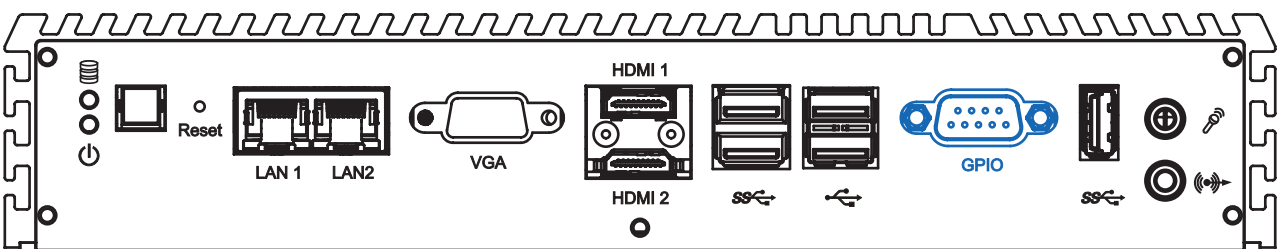

The ABP-2000 series offers an 8-bit DIO connector. Each bit internal pull up a weak resistor to +V3.3_SB. Each bit can be configured for DO or DI you can find the setting in BIOS.

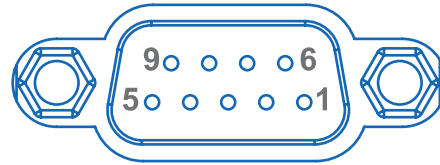

GPIO

Pin No.	Definition	Mapping to SIO GPIO Function
1	GPIO 0	SIO_GPI70
2	GPIO 1	SIO_GPI71
3	GPIO 2	SIO_GPI72
4	GPIO 3	SIO_GPI73
5	GND	GND
6	GPIO 4	SIO_GPI74
7	GPIO 5	SIO_GPI75
8	GPIO 6	SIO_GPI76
9	GPIO 7	SIO_GPI76

2.2.10 Audio Connectors

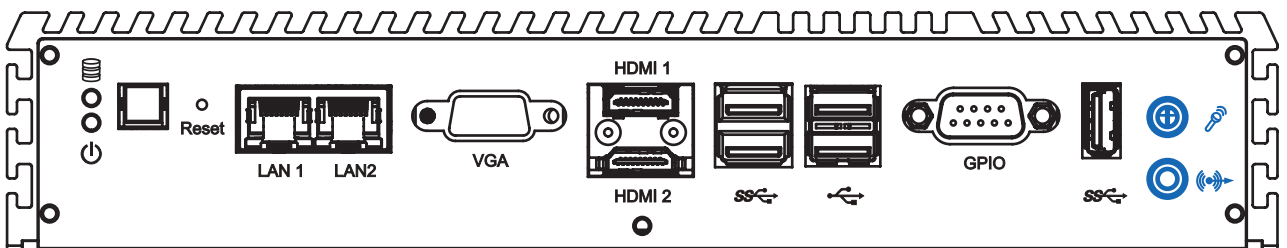

The ABP-2000 series offers stereo audio connectors of MIC and Line-In. The audio chip controller is by ALC888S-VD which is compliant with the Intel® Azalia standard. To utilize the audio function in Windows, you need to install corresponding drivers for Realtek® ALC888S-VD codec.

2.3 Rear Side External I/O Connectors

Figure 2.3.1 ABP-2845 Rear Panel

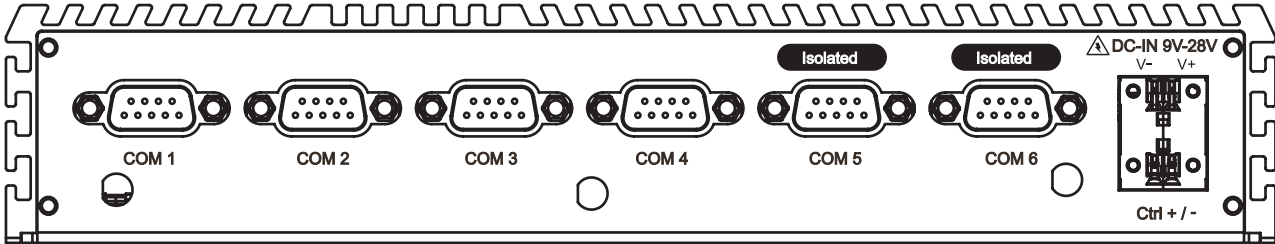

Figure 2.3.2 ABP-2045 Rear Panel

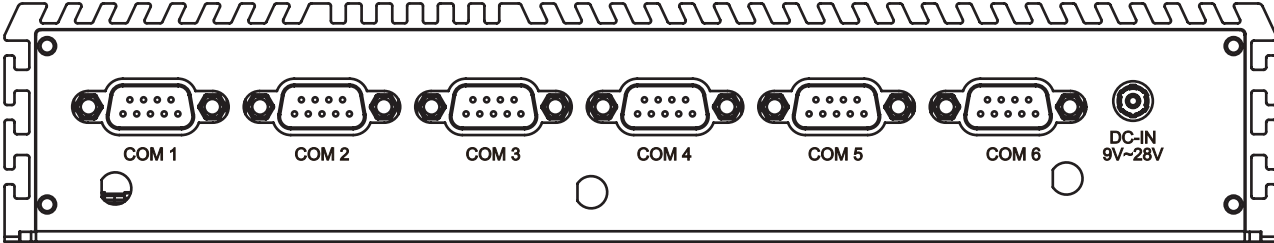
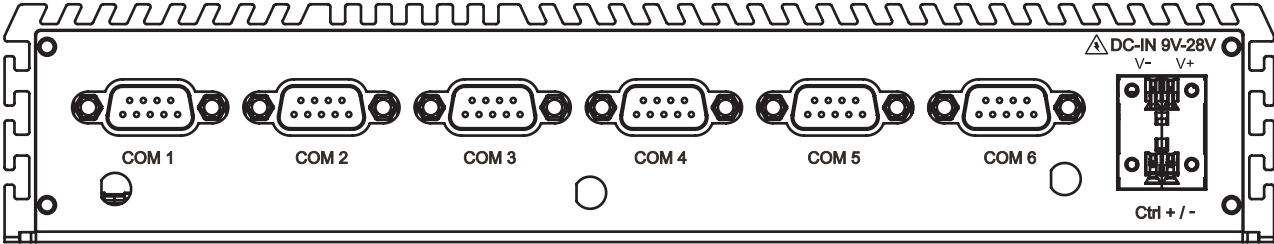
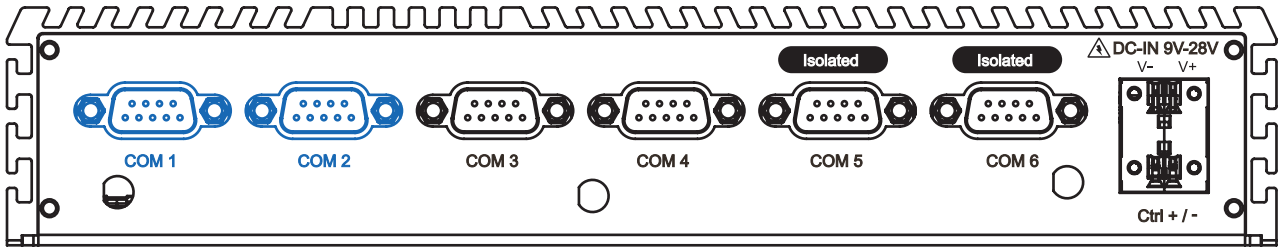

Figure 2.3.3 ABP-2015 Rear Panel



2.3.1 Serial Ports COM1 and COM2



COM1 and COM2 are RS-232 only and provide up to 115200 bps baud rates. The pin assignments are shown in the following table:

Serial Port	Pin No.	RS-232
COM1, 2	1	DCD
	2	RXD
	3	TXD
	4	DTR
	5	GND
	6	DSR
	7	RTS
	8	CTS
	9	RI

2.3.2 Serial Ports COM3 and COM4

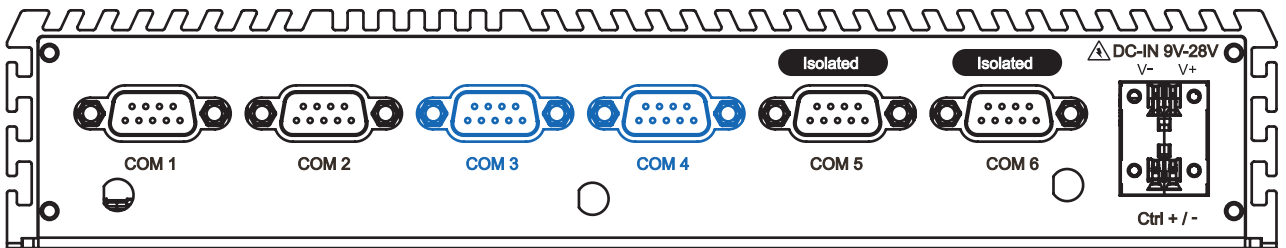

COM3 and COM4 can be configured for RS-232, RS-422, or RS-485 with auto flow control communication. Serial Port 3 & 4 default setting are RS-232, if you want to use RS-422 or RS-485, you can find the setting in BIOS.

BIOS Setting	Function
COM3 COM4	RS-232
	RS-422 (5-wire)
	RS-422 (9-wire)
	RS-485
	RS-485 w/z auto-flow control

The pin assignments are shown in the following table:

Serial Port	Pin No.	RS-232	RS-422 (5-Wire)	RS-422 (9-Wire)	RS-485 (3-Wire)
3.4	1	DCD	TXD-	TXD-	DATA-
	2	RXD	TXD+	TXD+	DATA+
	3	TXD	RXD+	RXD+	-----
	4	DTR	RXD-	RXD-	-----
	5	GND	GND	GND	GND
	6	DSR	-----	RTS-	-----
	7	RTS	-----	RTS+	-----
	8	CTS	-----	CTS+	-----
	9	RI	-----	CTS-	-----

2.3.3 Isolated Serial Port COM5 | COM6

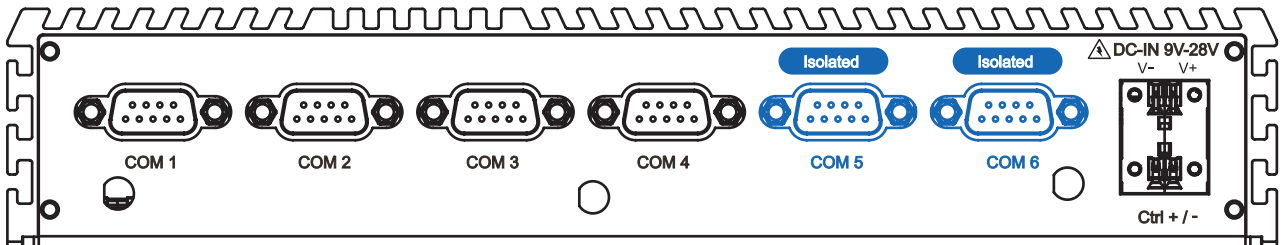

Only **ABP-2845** provides Isolated serial ports COM5 | COM6. COM5 and COM6 can be configured for RS-232, RS-422, or RS-485 with auto flow control communication. Serial Port 5 and 6 default setting are RS-232, if you want to use RS-422 or RS-485, you can find the setting in BIOS.

BIOS Setting	Function
COM5 COM6	RS-232
	RS-422 (5-wire)
	RS-422 (9-wire)
	RS-485
	RS-485 w/z auto-flow control

The pin assignments are shown in the following table:

Serial Port	Pin No.	RS-232	RS-422 (5-Wire)	RS-422 (9-Wire)	RS-485 (3-Wire)
2	1	DCD	TXD-	TXD-	DATA-
	2	RXD	TXD+	TXD+	DATA+
	3	TXD	RXD+	RXD+	-----
	4	DTR	RXD-	RXD-	-----
	5	GND	GND	GND	GND
	6	DSR	-----	RTS-	-----
	7	RTS	-----	RTS+	-----
	8	CTS	-----	CTS+	-----
	9	RI	-----	CTS-	-----

2.3.4 DC-IN 9~28V 5.5Ø DC Jack or Terminal Block

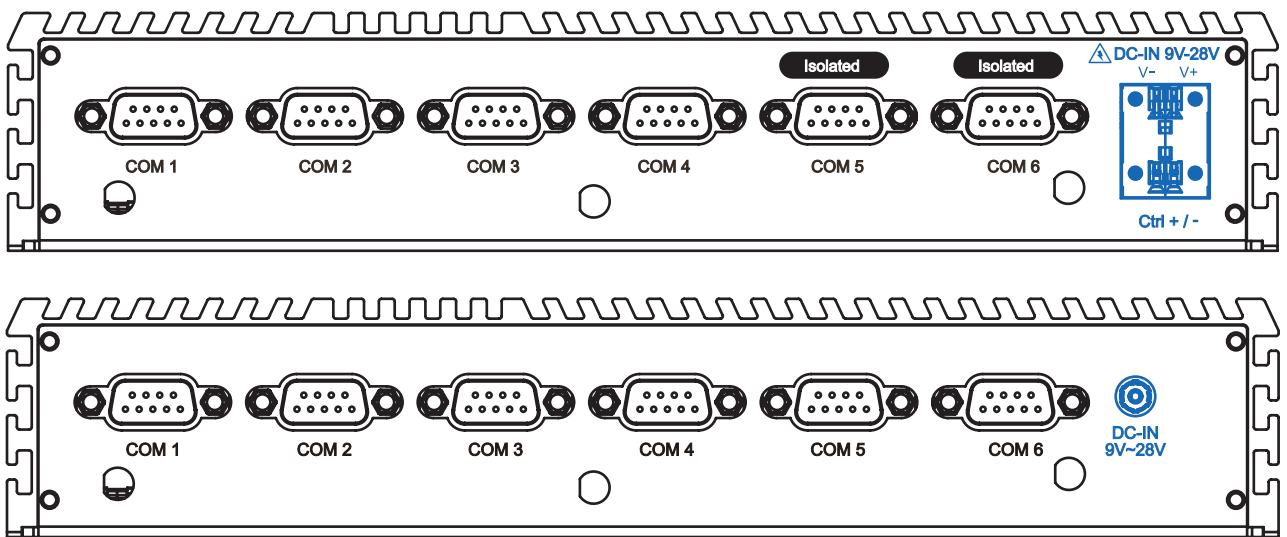

The ABP-2000 series offers 9 to 28 VDC power input, ABP-2845 and ABP-2015 are Terminal Block, ABP-2045 is DC Jack connector. If the power is supplied properly, the Power LED will light up a solid green.

2.4 Main Board Expansion Connectors

The figure below is the top view of the ABP-2000 series main board. It shows the location of the connectors.

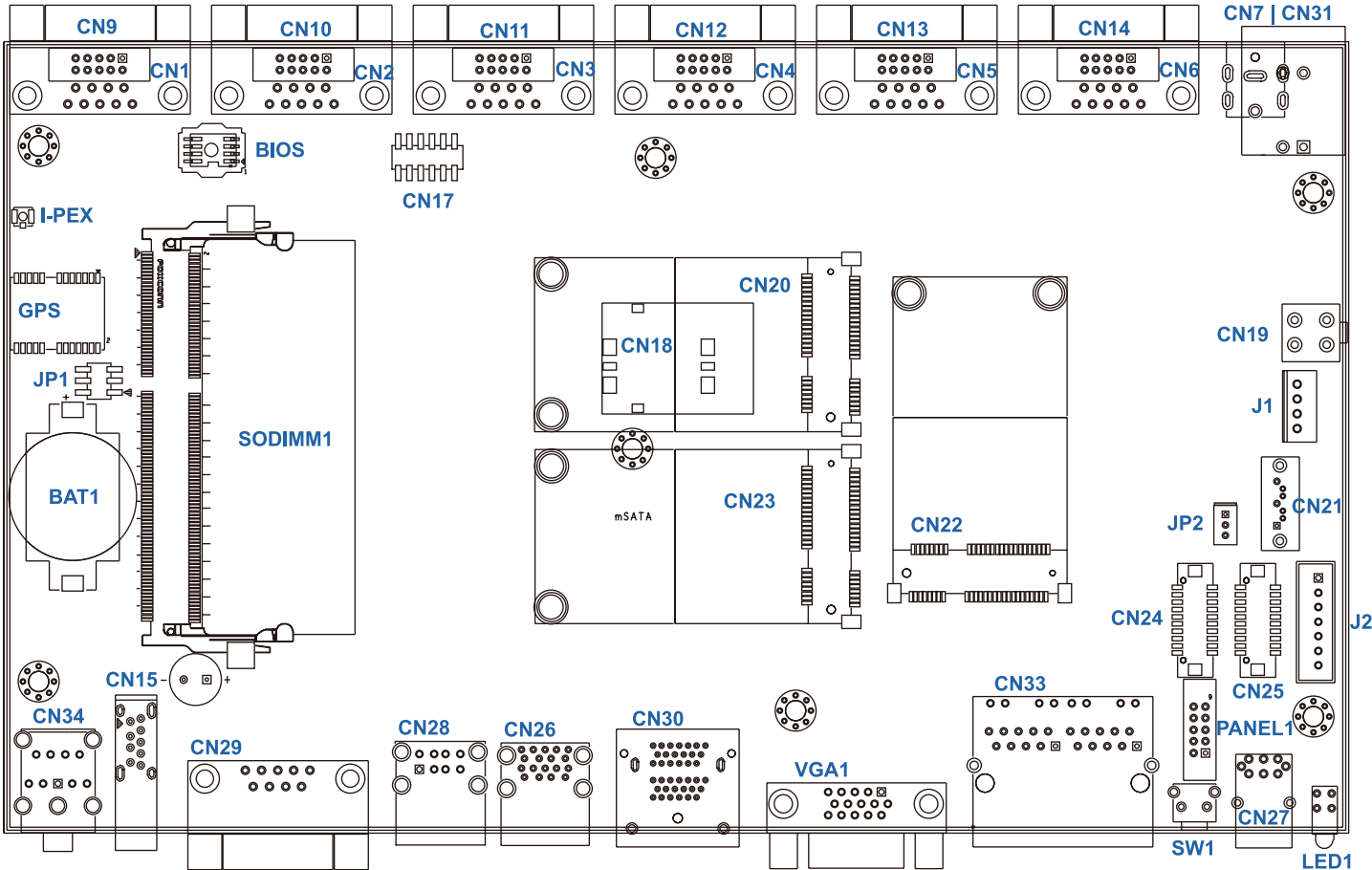
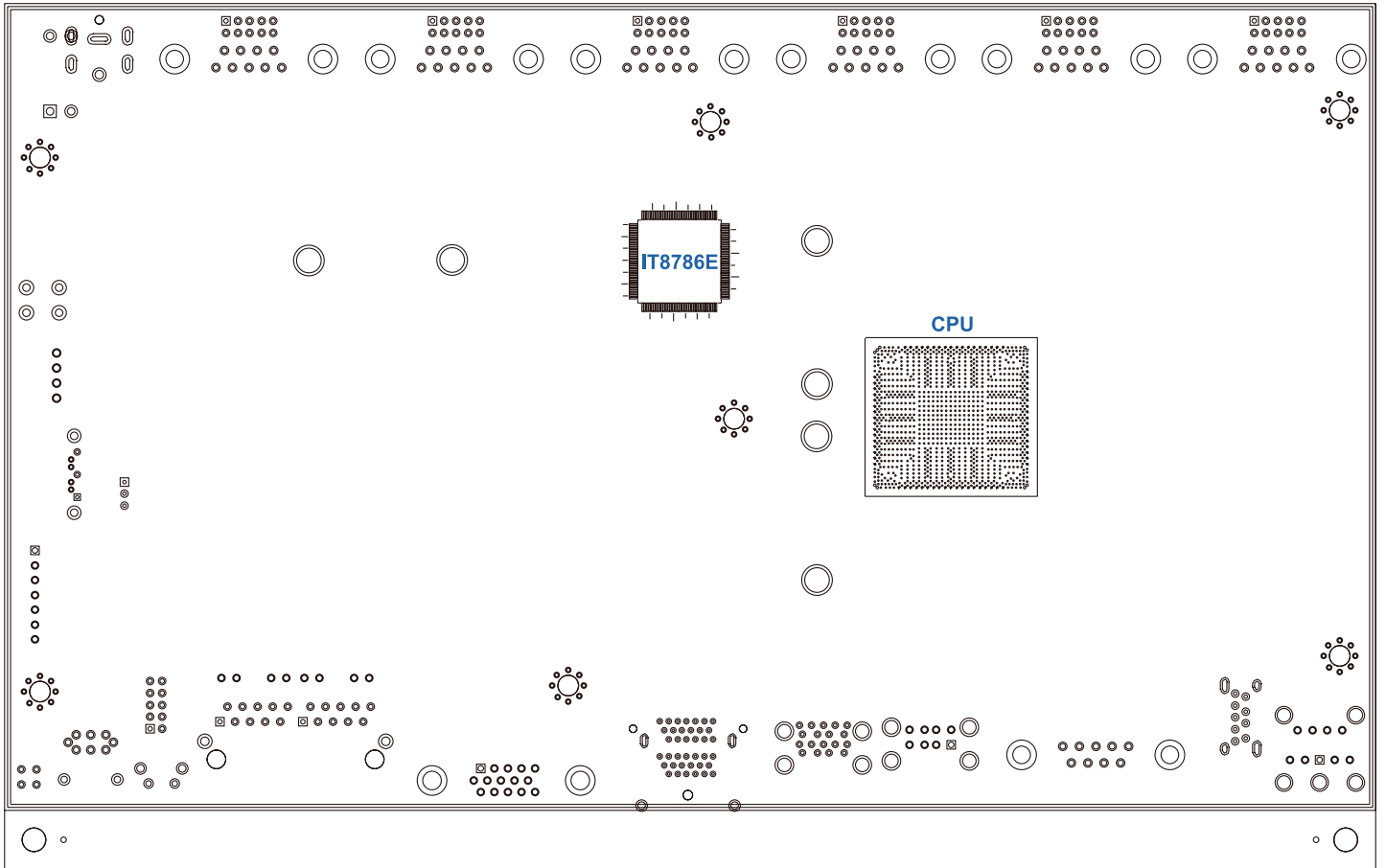
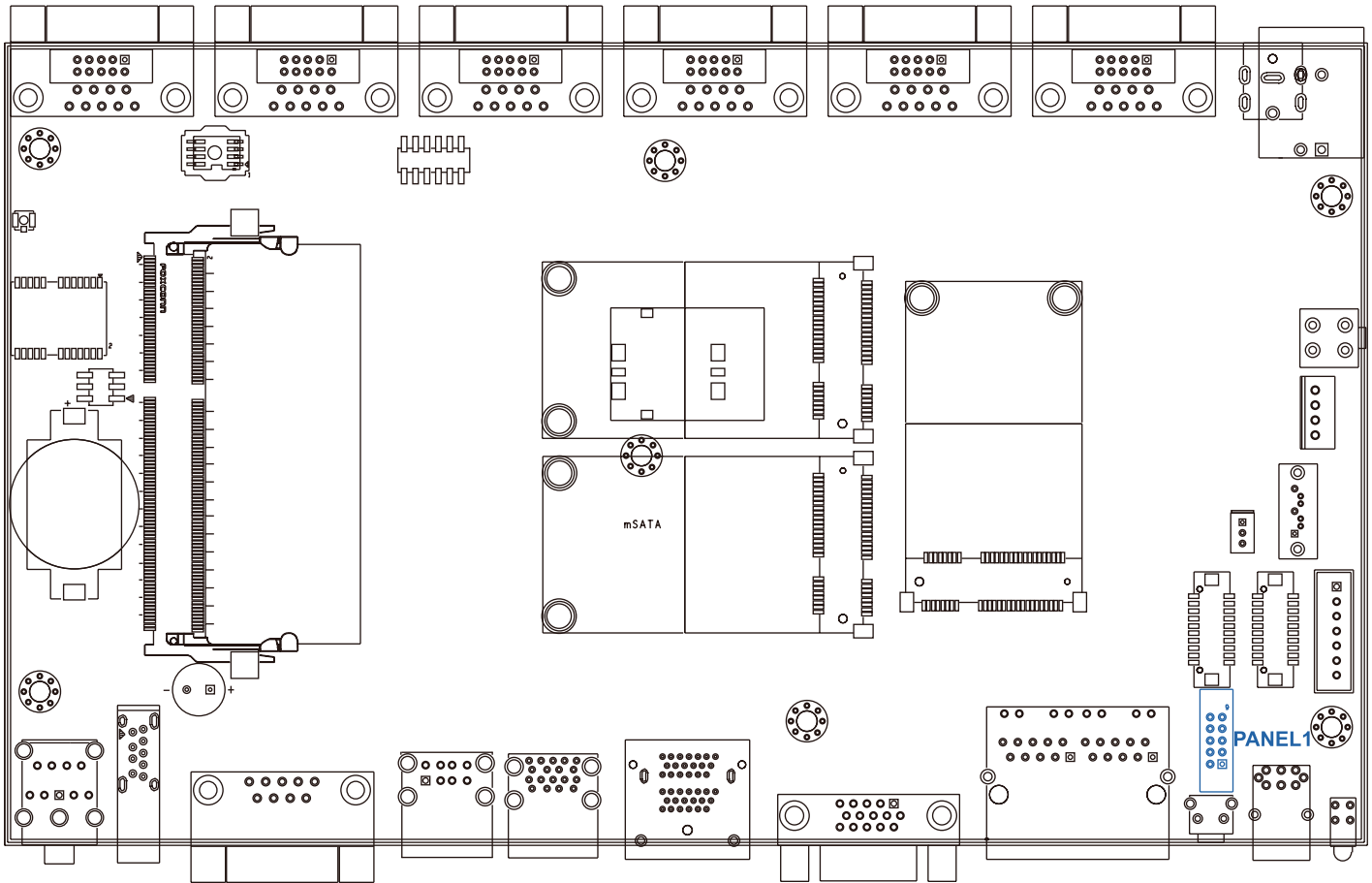

Figure 2.4.1 Internal Connectors and Jumpers

The figure below is the bottom view of the ABP-2000 series main board.



2.4.1 PANEL 1 Miscellaneous Pin Header



These pin headers can be used as a backup for the following functions: hard drive LED indicator, reset button, power LED indicator, and power-on/off button. The front and top panel already provides access to these functions. The following table shows the pinouts for Miscellaneous port.

J1 Miscellaneous Pin Header

Group	Pin No.	Description
HDD LED	2	HDD_LED+
	4	HDD_LED-
RESET BUTTON	6	FP_RST_BTN_N
	8	GND
POWER LED	1	PWR_LED+
	3	PWR_LED-
POWER BUTTON	5	FP_PWR_BTN_N
	7	GND
POWER	9	+V5
	10	+V5_SB

2.4.2 CN24, CN25, J2 LVDS

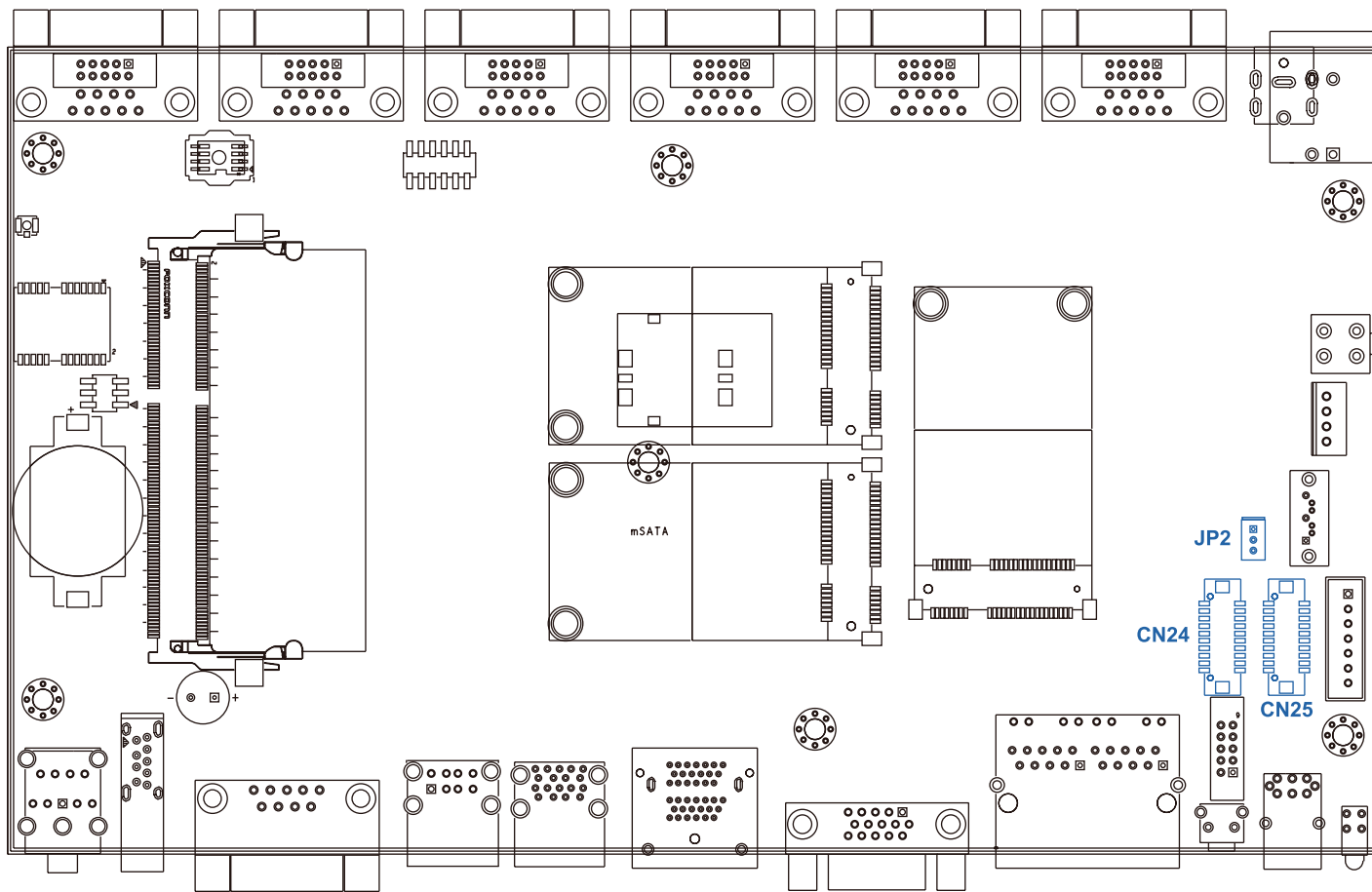

The ABP-2000 series supports Dual-channel 24-bit LVDS Panel up to 1920x1200 pixels panel resolution.

Pin No.	Definition	
	CN24 Channel A	CN25 Channel
1	LDDC_CLK	LDDC_CLK
2	LDDC_DATA	LDDC_DATA
3	PANEL_VDD (+3.3V or +5V by JP2 jumper)	PANEL_VDD(+3.3V or +5V by JP2 jumper)
4	LA_DATA0_P	LB_DATA0_P
5	LA_DATA3_P	LB_DATA3_P
6	LA_DATA0_N	LB_DATA0_N
7	LA_DATA3_N	LB_DATA3_N
8	PANEL_VDD (+3.3V or +5V by JP2 jumper)	PANEL_VDD (+3.3V or +5V by JP2 jumper)
9	GND	GND
10	LA_DATA1_P	LB_DATA1_P
11	LA_CLKP	LB_CLKP
12	LA_DATA1_N	LB_DATA1_N
13	LA_CLKN	LB_CLKN
14	GND	GND
15	GND	GND
16	PANEL_BACKLIGHT (+12V)	PANEL_BACKLIGHT (+12V)
17	LA_DATA2_P	LB_DATA2_P

Pin No.	Definition	
	CN24 Channel A	CN25 Channel
18	PANEL_BACKLIGHT (+12V)	PANEL_BACKLIGHT (+12V)
19	LA_DATA2_N	LB_DATA2_N
20	GND	GND

The LCD inverter is connected to J2 via a JST 7-pin, 2.5mm connector to provide +5V/+12V power to the LCD display.

Pin No.	Definition
1	+5V
2	+12V
3	+12V
4	LBKLT_CTL
5	GND
6	GND
7	LBKLT_EN

2.4.3 CN21 SATA II Connector & J1 SATA Power Connector

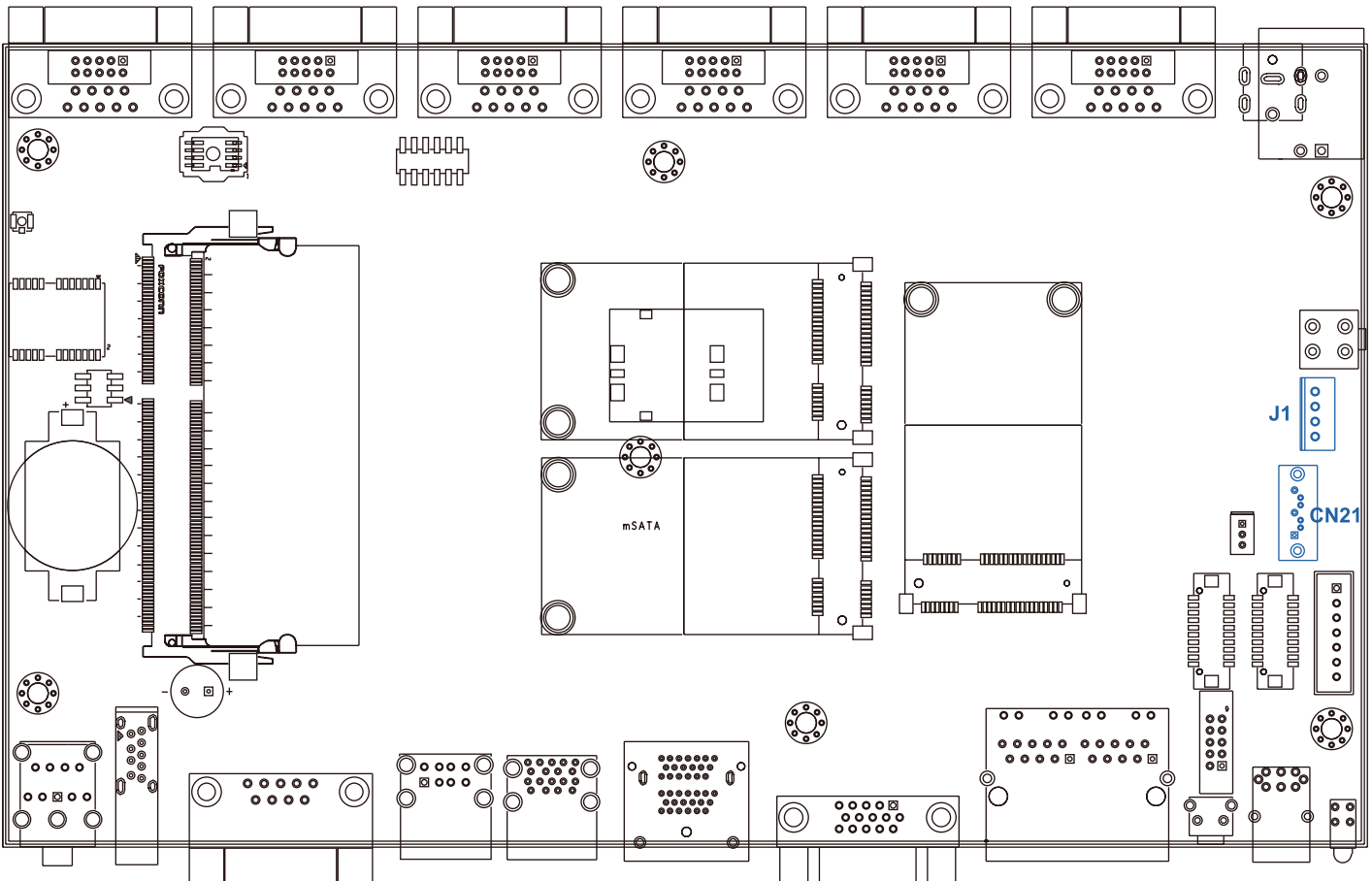

The ABP-2000 series features two high performance Serial ATA II interfaces that eases cabling to hard drives or SSD with thin and short cables while application need larger storage capacity.

Pin No.	Definition
1	GND
2	TXP
3	TXN
4	GND
5	RXN
6	RXP
7	GND

The ABP-2000 series is equipped with one SATA power connector. It supply 5V (1A max.) and 12V (1A max) current to the hard drive or SSD.

CN21 SATA HDD Power Connector

Pin No.	Definition
1	+12V
2	GND
3	GND
4	+5V

2.4.4 CN23 mSATA Connector

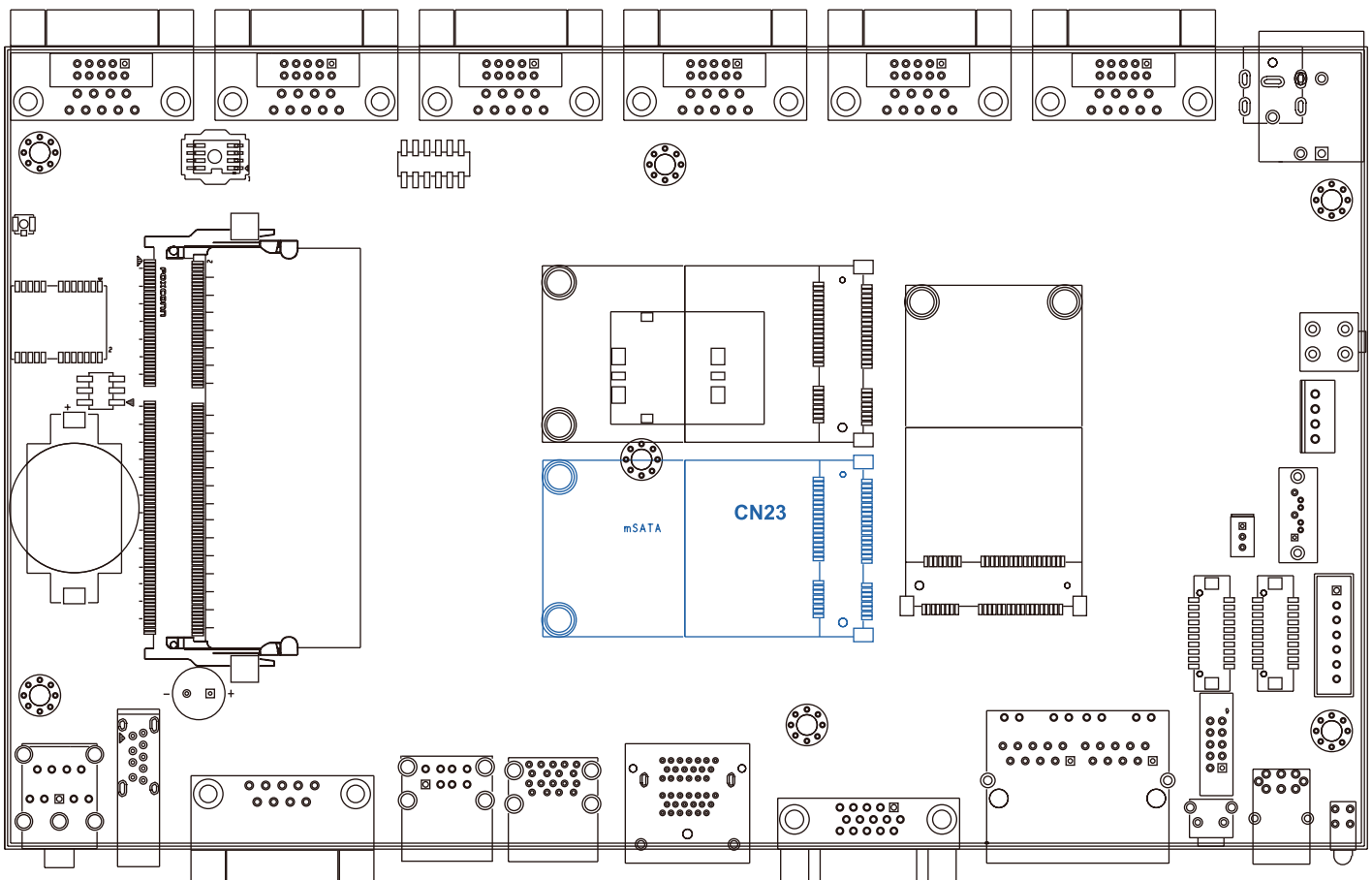

It is for connecting an eSATA storage device. There was no clear mechanism to distinguish if a mSATA drive or a Mini PCI-E device is plugged into the socket until recently that SATA-IO issued an ECN change (ECN #045) to re-define pin 43 on mSATA connector as “no connect” instead of “return current path” (or GND).

When an mSATA drive is inserted, its pin 43 is “no connect”, and the respective pin on the socket is being pulled-up to logic 1. When a Mini PCI-E device is inserted, its pin 43 forces the respective pin on the socket to ground, or logic 0.

CN23 mSATA Connector Pin-Out

Pin No.	Signal Name	Pin No.	Signal Name	Pin No.	Signal Name	Pin No.	Signal Name
51	NC	52	+3.3Vaux	33	SATA_TXp	34	GND
49	NC	50	GND	31	SATA_TXn	32	NC
47	NC	48	+1.5V	29	GND	30	NC
45	NC	46	NC	27	GND	28	+1.5V
43	GND	44	NC	25	SATA_RXp	26	GND
41	+3.3Vaux	42	NC	23	SATA_RXn	24	+3.3Vaux
39	+3.3Vaux	40	GND	21	GND	22	NC
37	GND	38	NC	19	NC	20	NC
35	GND	36	NC	17	NC	18	GND
Mechanical Key							
15	GND	16	NC	7	NC	8	NC
13	NC	14	NC	5	NC	6	1.5V
11	NC	12	NC	3	NC	4	GND
9	GND	10	NC	1	NC	2	3.3Vaux

2.4.5 CN20, CN22, mini-PCle Connectors

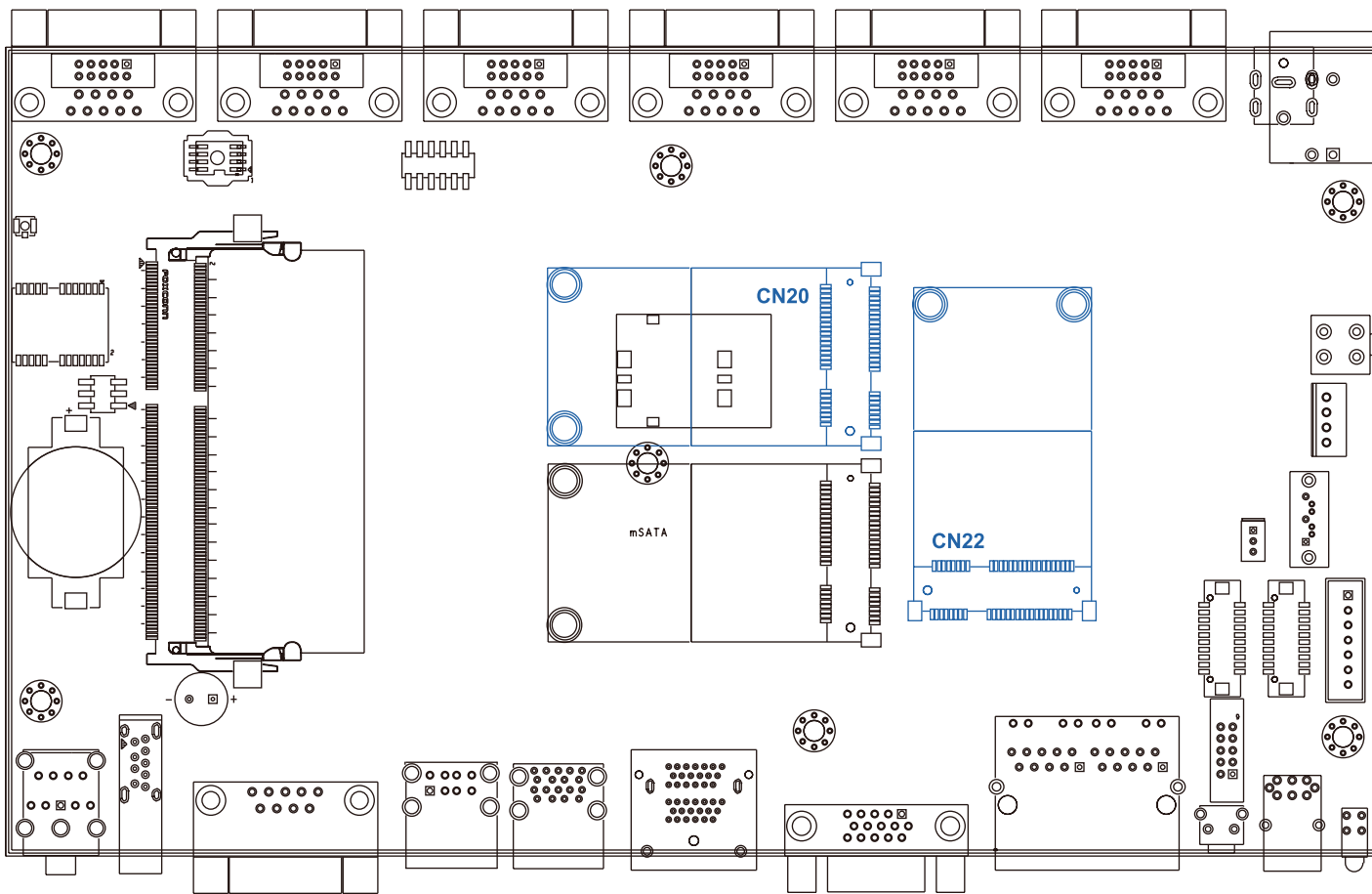

CN20 Mini-PCle Connector Pin-Out

Pin No.	Signal Name	Pin No.	Signal Name	Pin No.	Signal Name	Pin No.	Signal Name
51	NC	52	+3.3Vaux	33	PETp0	34	GND
49	NC	50	GND	31	PETn0	32	SMB_DATA
47	NC	48	+1.5V	29	GND	30	SMB_CLK
45	NC	46	NC	27	GND	28	+1.5V
43	GND	44	NC	25	PERp0	26	GND
41	+3.3Vaux	42	NC	23	PERn0	24	+3.3Vaux
39	+3.3Vaux	40	GND	21	GND	22	PERST#
37	GND	38	USB_D+	19	NC	20	NC
35	GND	36	USB_D-	17	NC	18	GND

Mechanical Key

15	GND	16	UIM_VPP	7	CLKREQ#	8	UIM_PWR
13	REFCLK+	14	UIM_RST	5	NC	6	1.5V
11	REFCLK-	12	UIM_CLK	3	NC	4	GND
9	GND	10	UIM_DATA	1	WAKE#	2	3.3Vaux

CN22 Mini-PCle Connector Pin-Out

Pin No.	Signal Name	Pin No.	Signal Name	Pin No.	Signal Name	Pin No.	Signal Name
51	NC	52	+3.3Vaux	33	PETp0	34	GND
49	NC	50	GND	31	PETn0	32	SMB_DATA
47	NC	48	+1.5V	29	GND	30	SMB_CLK
45	NC	46	NC	27	GND	28	+1.5V
43	GND	44	NC	25	PERp0	26	GND

Pin No.	Signal Name	Pin No.	Signal Name	Pin No.	Signal Name	Pin No.	Signal Name
41	+3.3Vaux	42	NC	23	PERn0	24	+3.3Vaux
39	+3.3Vaux	40	GND	21	GND	22	PERST#
37	GND	38	USB_D+	19	NC	20	NC
35	GND	36	USB_D-	17	NC	18	GND
Mechanical Key							
15	GND	16	NC	7	CLKREQ#	8	NC
13	REFCLK+	14	NC	5	NC	6	1.5V
11	REFCLK-	12	NC	3	NC	4	GND
9	GND	10	NC	1	WAKE#	2	3.3Vaux

2.4.6 CN29 GPIO

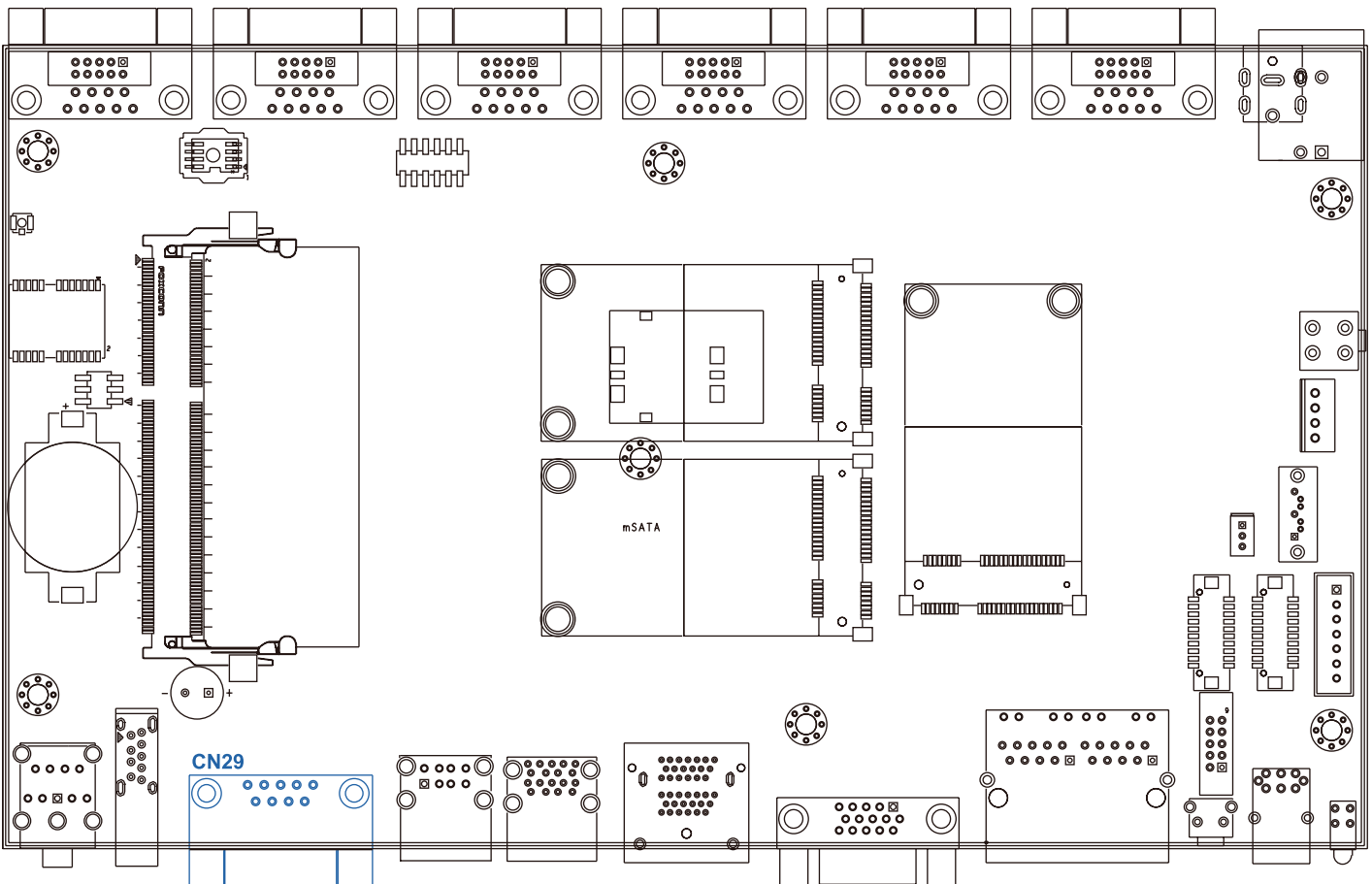

These pin headers can be used as a backup for the The ABP-2000 series offers 8 programmable I/O within TTL 3.3V tolerance. If the GPIO is logic high, it indicates that the mapping SIO GPIO pin is logic high level. If the GPIO is logic low, it indicates that the mapping SIO GPIO pin is logic low level.

Pin No.	SIO GPIO Function
1	SIO_GPIO77
2	SIO_GPIO76
3	SIO_GPIO75
4	SIO_GPIO74

Pin No.	SIO GPIO Function
5	SIO_GPIO73
6	SIO_GPIO72
7	SIO_GPIO71
8	SIO_GPIO70
9	GND

2.4.7 Battery

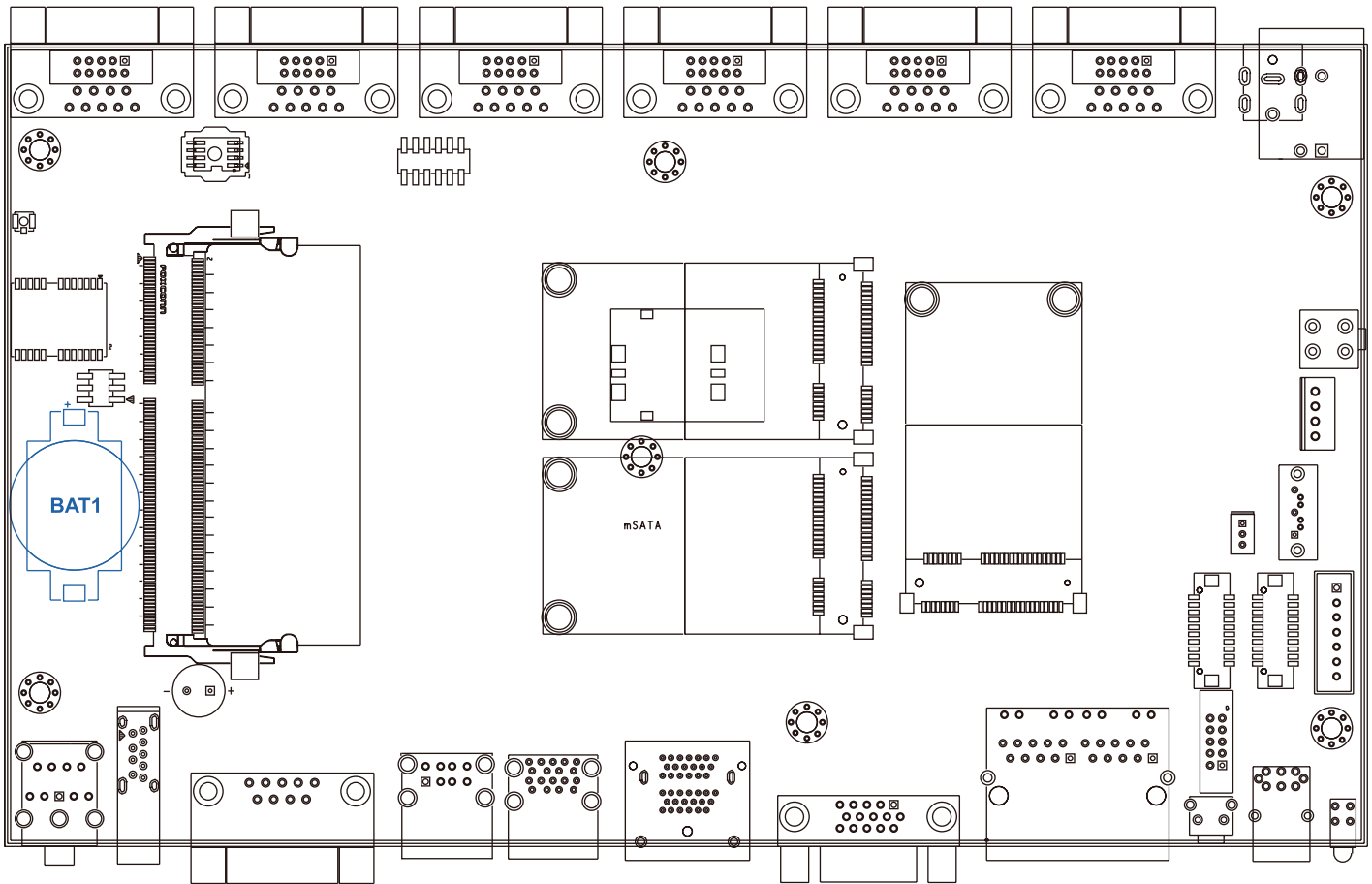

The ABP-2000 series' real-time clock is powered by a lithium battery. It is Equipped with Panasonic BR2032 190mAh lithium battery. It is recommended that you not replace the lithium battery on your own. If the battery needs to be changed, please contact the Vecow RMA service team.

2.4.8 GPS Module

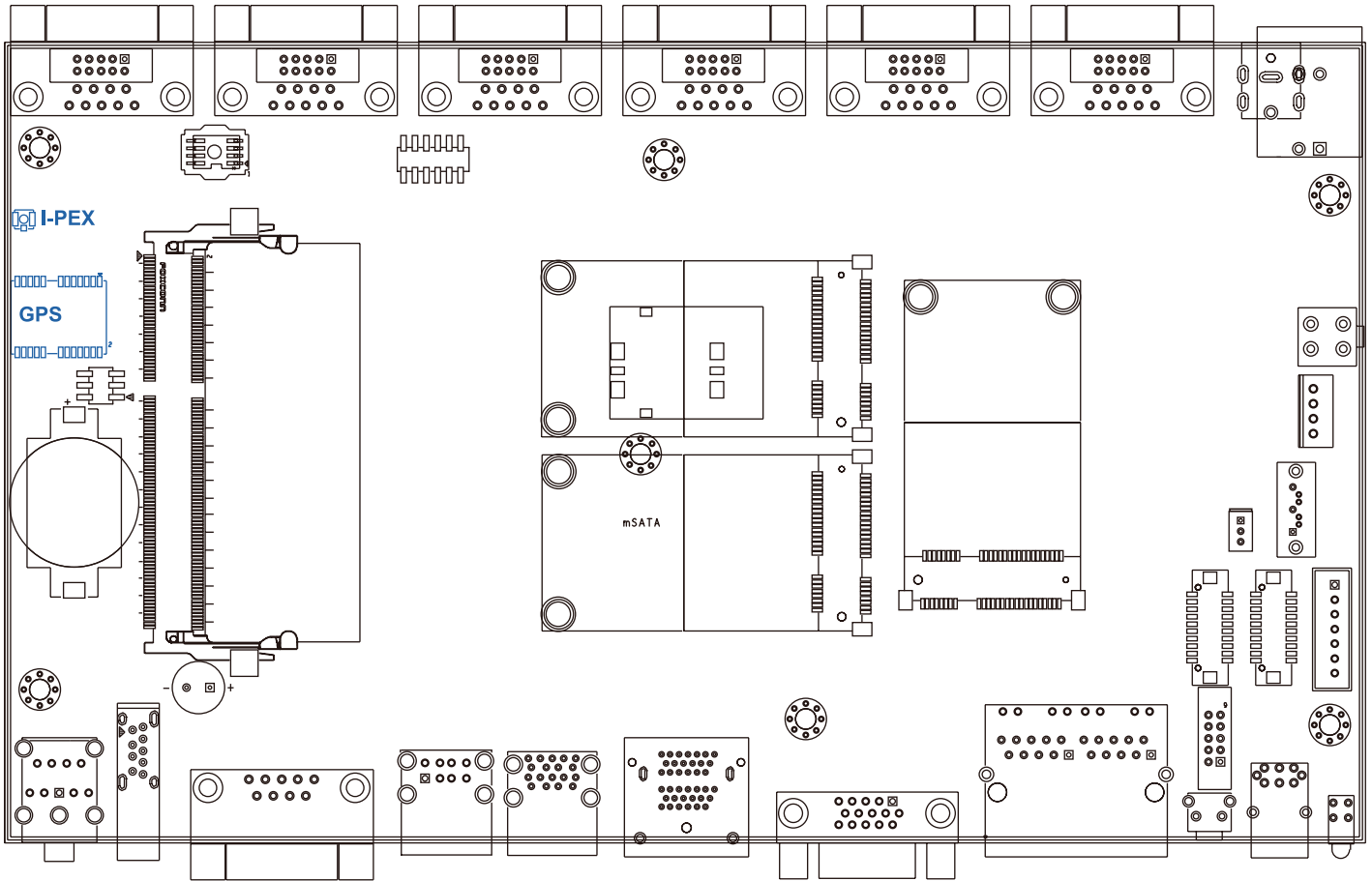

The ABP-2000 series offers a u-blox NEO-7 GPS/GNSS modules (can upgrade to NEO-8) and 2.0mm diameter I-PEX antenna connector with 3.3 voltage power. Antenna circuit as follows.

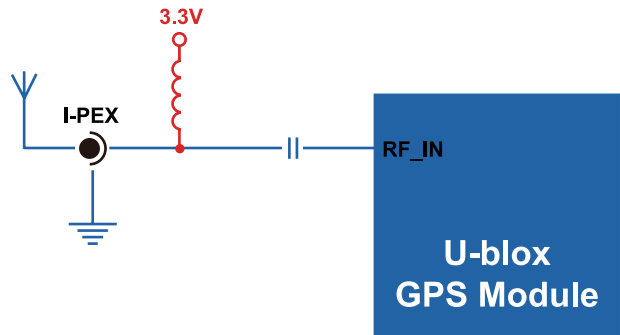

2.5 Main Board Jumper Setting

The figure below is the top view of the ABP-2000 series main board. It shows the location of the jumpers.

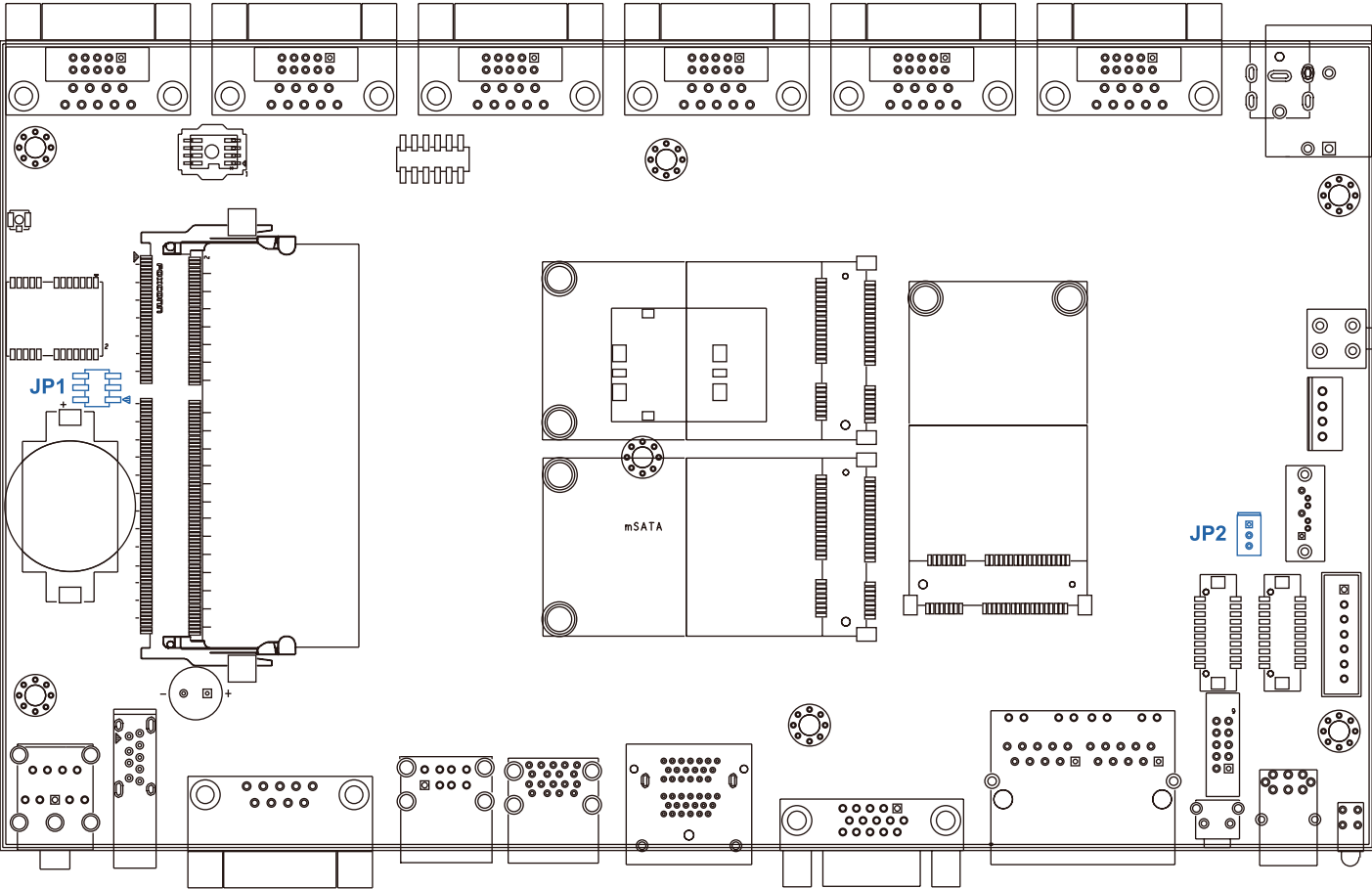

You may configure your card to match the needs of your application by setting jumpers. A jumper is a metal bridge used to close an electric circuit.

It consists of two metal pins and a small metal clip (often protected by a plastic cover) that slides over the pins to connect them.

To “close” a jumper, you connect the pins with the clip. To “open” a jumper, you remove the clip. Sometimes a jumper will have three pins, labeled 1, 2 and 3. In this case you would connect either pins 1 and 2, or 2 and 3.

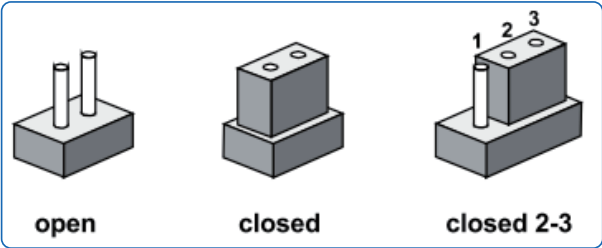

2.5.1 JP1(A) CMOS Clear Jumper Setting

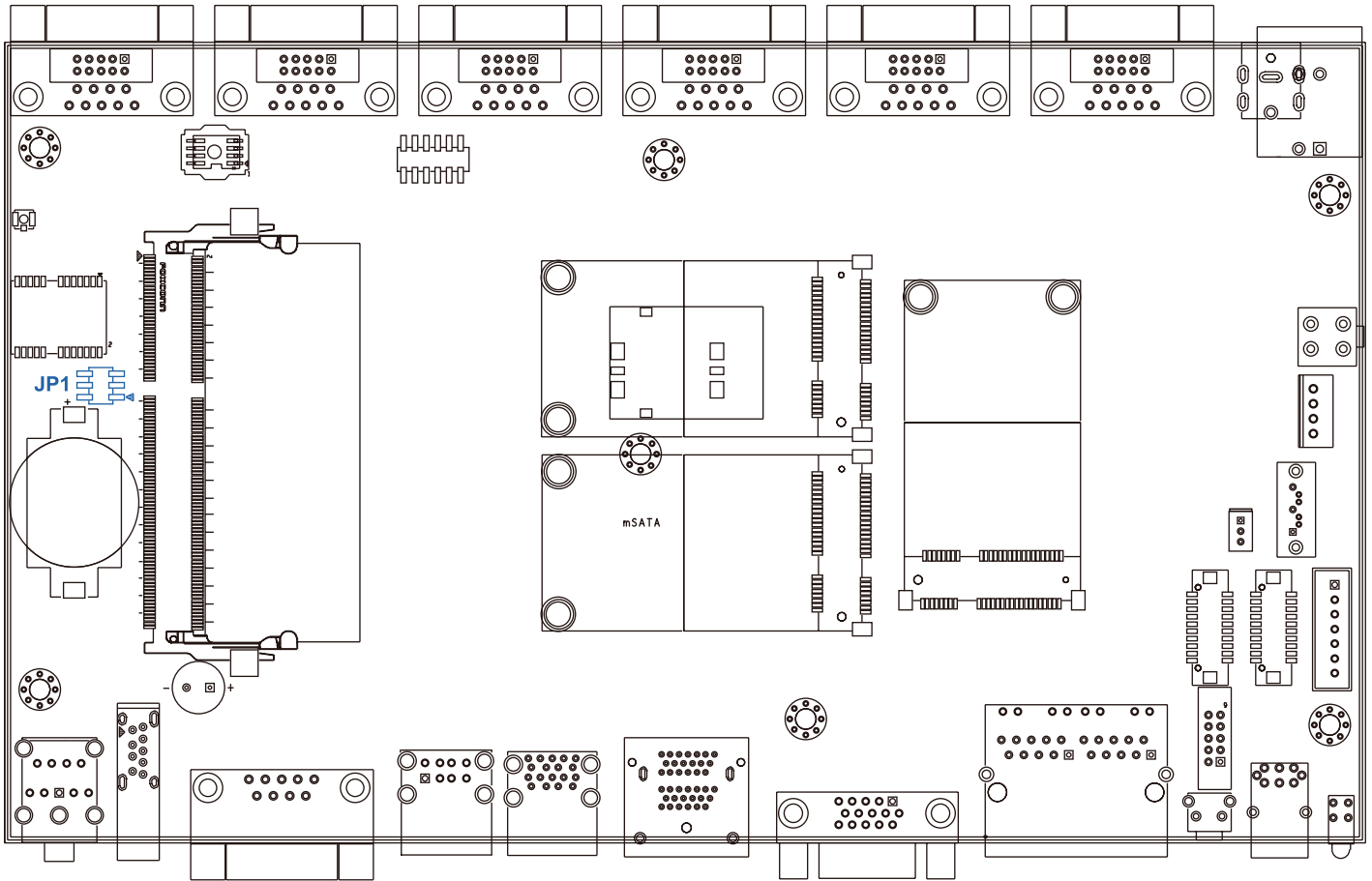

Setting	Description
1-3	Normal (Default)
3-5	Clear CMOS

2.5.2 JP1(B) ME Clear Jumper Setting

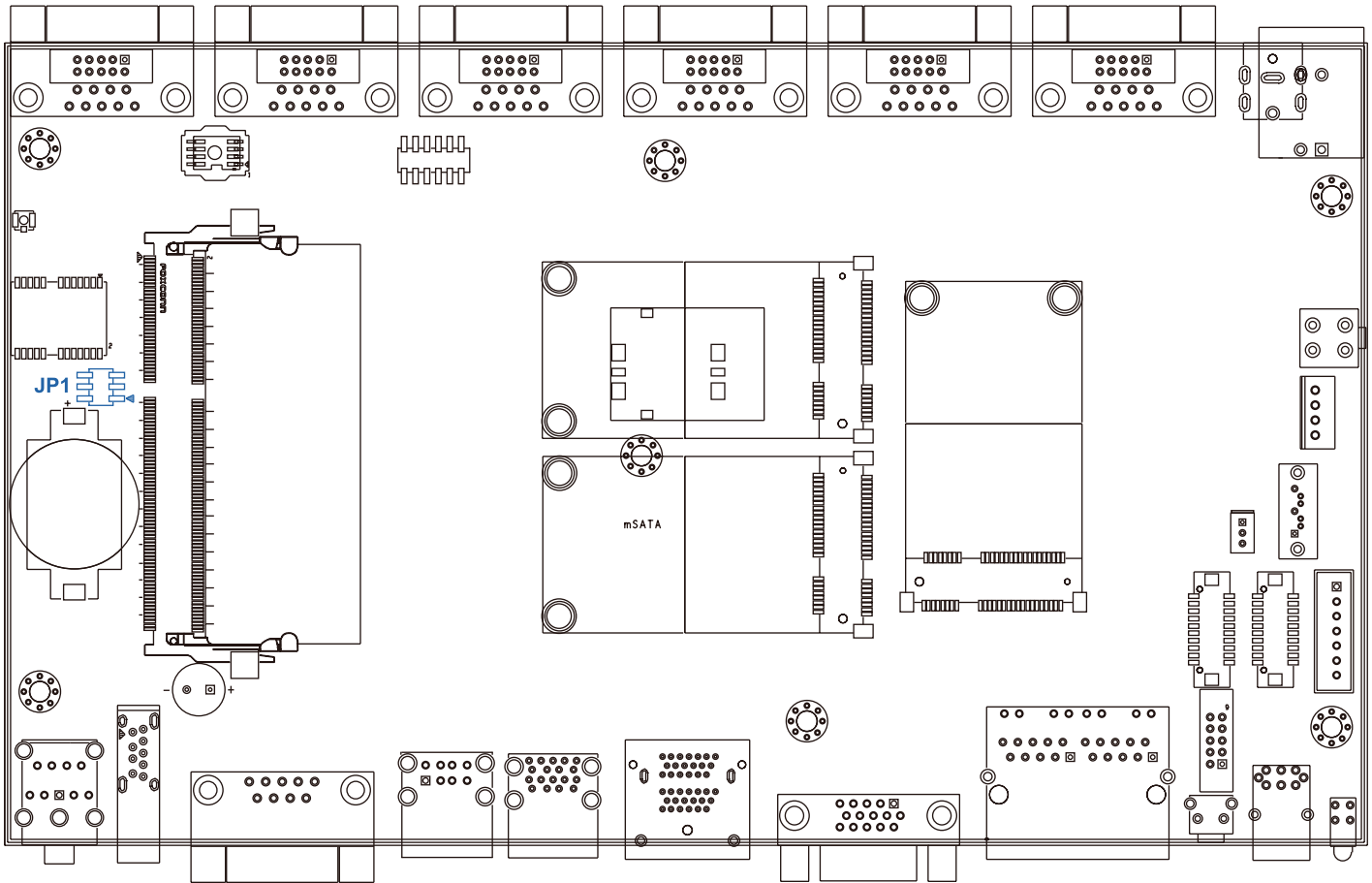

Setting	Description
2-4	Normal (Default)
4-6	Clear ME

2.5.3 JP2 LVDS Backlight Power Selection

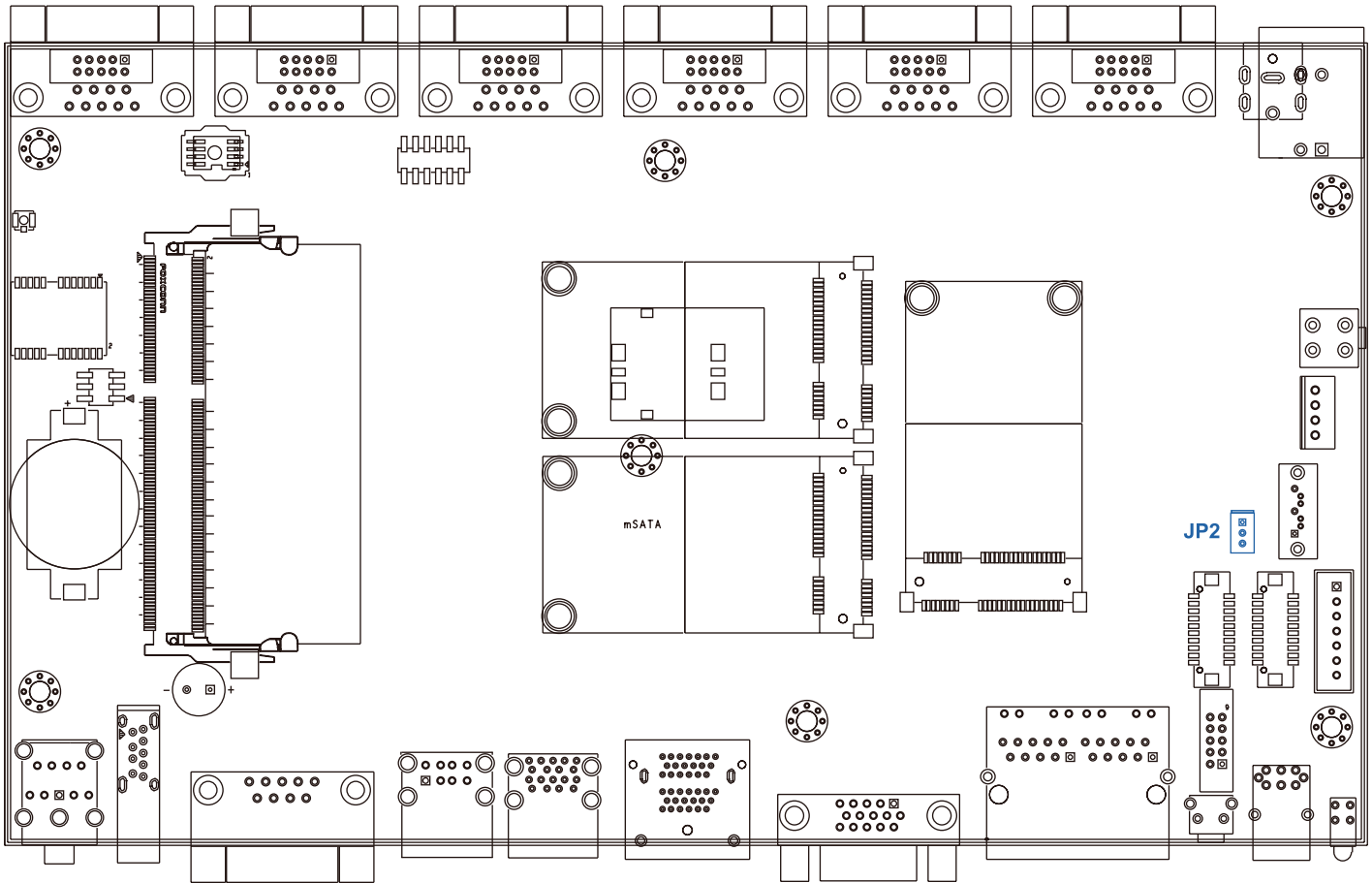

JP2 provides LVDS voltage selection function, closing Pin 1, 2 is for 3.3V LVDS power input; closing Pin 2, 3 is for 5V LVDS power input.

Setting	Description
1-2	+3.3V (Default)
2-3	+5V

3

System Setup

3.1 Install DDR3 / DDR3L SODIMM Modules

Step1.



Put the ABP-2000 series upside down on a flat surface. You can see the “Pet-Door” exposed. Use a Philips screwdriver to loose the M3 flat-head screw on the “Pet-Door”.

Step2.

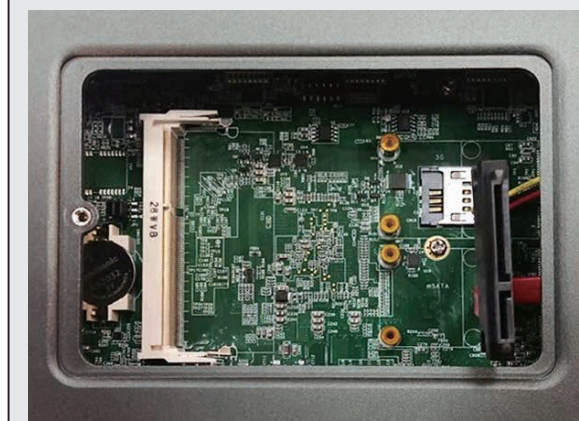

Remove the “Pet-Door” and you can see a DDR3 SODIMM socket exposed.

Step3.



Tile the SODIMM module and insert it to the SODIMM socket.



As it's firmly contacted with socket connectors, press it down until the clamps of the socket snap into the latching position of SODIMM module.

3.2 Install SSD | HDD

Step1.



Put the ABP-2000 series upside down on a flat surface. You can see the "Pet-Door" exposed. Use a Philips screwdriver to loose the M3 flat-head screw on the "Pet-Door".

Step2.

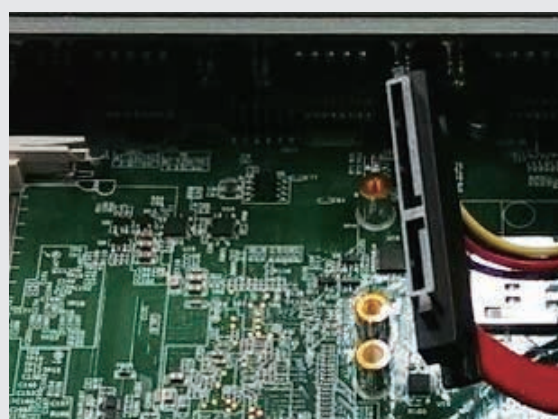

Remove the "Pet-Door" and you can see a DDR3 SODIMM socket exposed.

Step3.



Place the HDD into the bracket and gently push it down to make it contact with thermal pad. Use a Philips screwdriver to fix the HDD with M3 screws. Please note that the HDD must be placed in the right direction as below.

Step4.

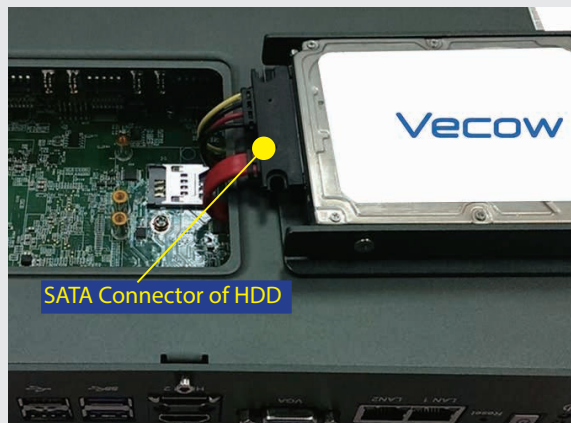

Pull out the SATA cable inside the chassis and connect it to HDD.

3.3 Mount Your ABP-2000

Installation Method 1

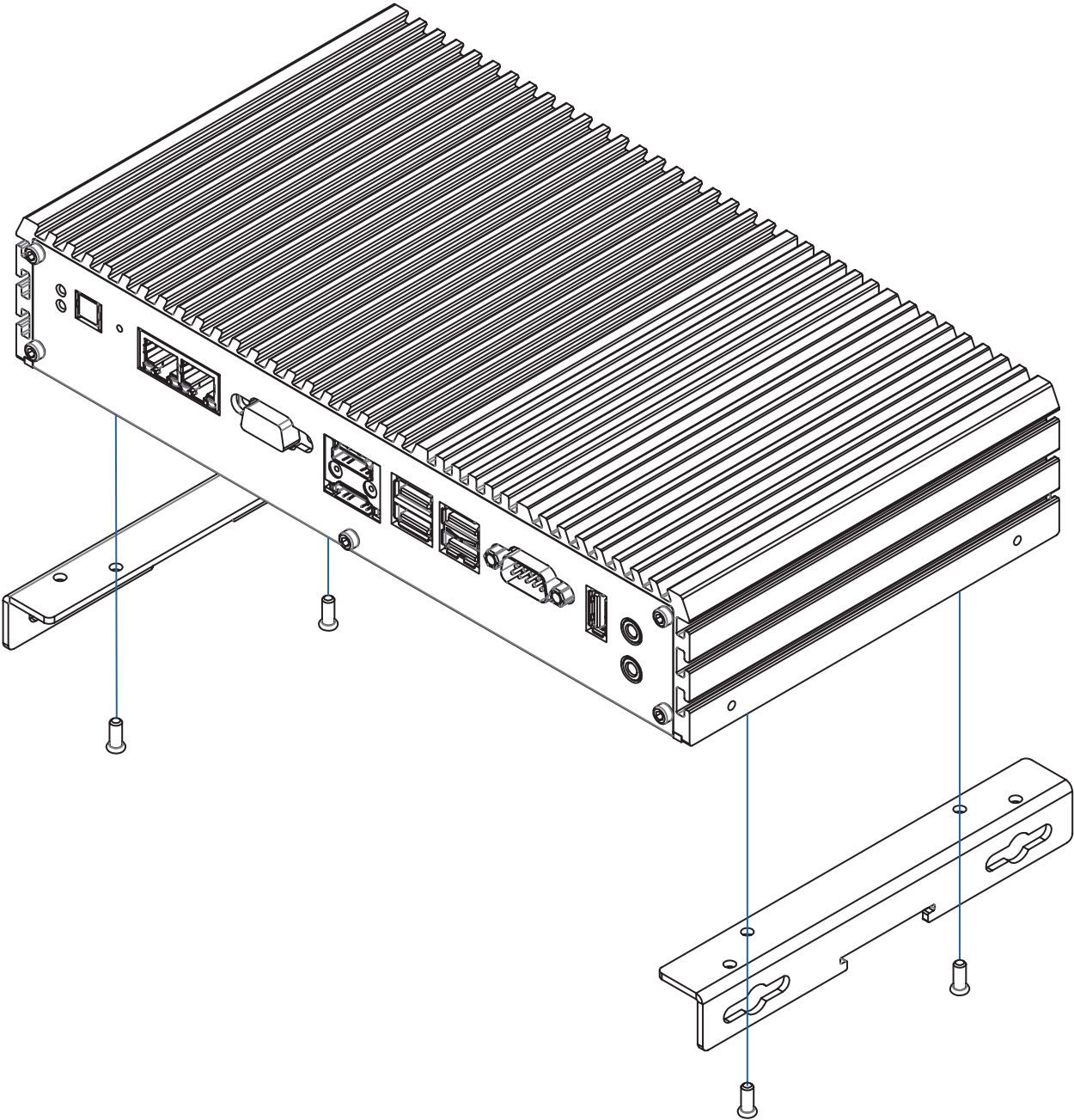

Installation Method 2

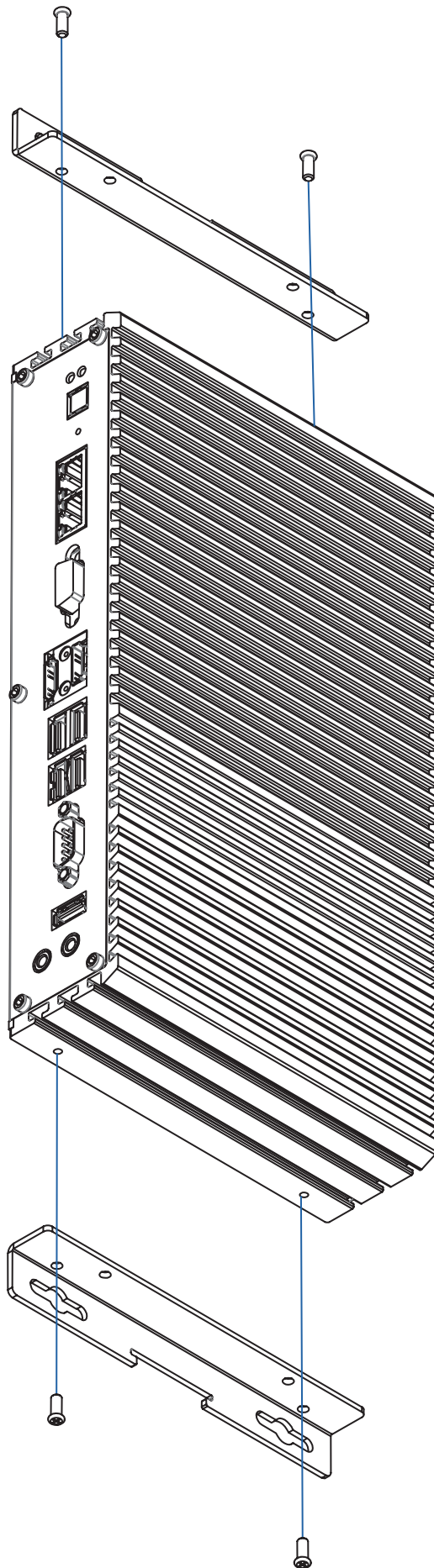

4

BIOS and Driver

4.1 BIOS Settings

The board uses UEFI BIOS that is use Serial Peripheral Interface (SPI) Flash. The SPI Flash contains the BIOS Setup program, POST, the PCI auto-configuration utility, LAN, EEPROM information, and Serial port support. The BIOS setup program is accessed by pressing the **** key after the Power-On Self-Test (POST) memory test begins and before the operating system boot begins. The menu bar is shown below.



Figure 4.1: BIOS Menu Bar

4.1.1 Main Menu

Aptio Setup Utility – Copyright (C) 2013 American Megatrends, Inc.		
Main	Advanced	Chipset Security Boot Save & Exit
BIOS Information		Item Specific Help
BIOS Vendor	Vecow ABP-2000 B20-001	
BIOS Version	5.008	
Release time	12/06/2013 09:39:15	
System Language	[English]	
System Date	[Thu 02/21/2013]	
System Time	[12:00:00]	

Figure 4.1.1: BIOS Main screen

System Time / Date : Press “TAB” key to switch sub-items of value .Then press “ +” key or “-“ key number key for modify value.

In this page , you could make sure you CPU type and DRAM type that you are install into this system.

4.2 Advanced Function

4.2.1 ACPI Setting

Aptio Setup Utility – Copyright (C) 2013 American Megatrends, Inc.		
Main	Advanced	Chipset Security Boot Save & Exit
ACPI Settings		Item Specific Help
Enable ACPI Auto Configuration	[Disabled]	
Enable Hibernation	[Enabled]	
ACPI Sleep State	[S3]	

Figure 4.2.1: ACPI Setting setup screen

Enable ACPI Auto Configuration: This system support ACPI function as auto process. You should Enable / Disable that depend as your O.S.

Enable Hibernation: It is able to use Hibernate function if O.S support. But some Operation system maybe not effective with this function.

ACPI Sleep state: Select sleep state while SUSPEND button pressed.

4.2.2 Serial Port 1 Configuration

Advanced->IT8786E Super IO Configuration->Serial Port 1 Configuration

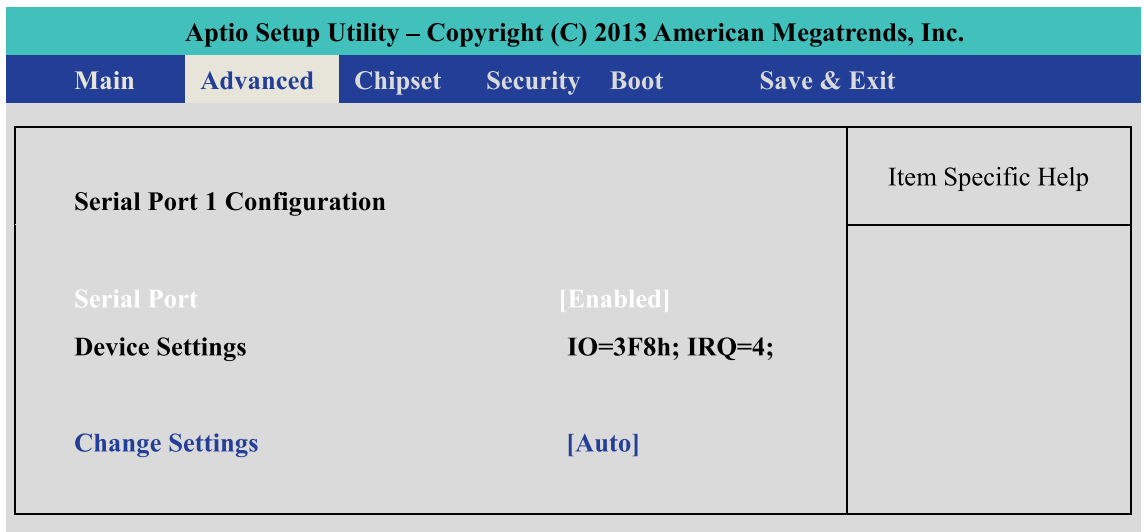

Figure 4.2.2: Serial Port 2 Setup screen

Serial Port :
Enable or Disable Serial port.

Device Setting:
Current IO addresses and interrupts resource of Serial Port.

Change Settings :
Select another device setting.
Here have 6 options :

- Auto
- IO=3F8h; IRQ=4;
- IO=3F8h; IRQ=3,4,5,6,7,8,9,10,11,12;
- IO=2F8h; IRQ=3,4,5,6,7,8,9,10,11,12;
- IO=3E8h; IRQ=3,4,5,6,7,8,9,10,11,12;
- IO=2E8h; IRQ=3,4,5,6,7,8,9,10,11,12;

4.2.3 Serial Port 2 Configuration

Advanced->IT8786E Super IO Configuration->Serial Port 1 Configuration

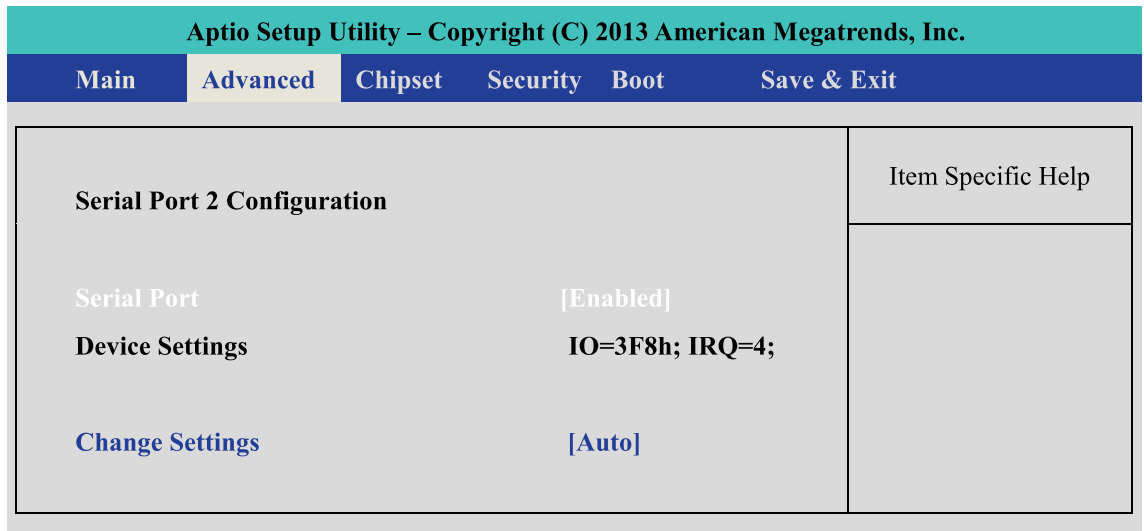

Figure 4.2.3: Serial Port 1 Setup screen

Serial Port :

Enable or Disable Serial port.

Device Setting:

Current IO addresses and interrupts resource of Serial Port.

Change Settings :

Select another device setting.

Here have 6 options :

Auto

IO=3F8h; IRQ=4;

IO=3F8h; IRQ=3,4,5,6,7,8,9,10,11,12;

IO=2F8h; IRQ=3,4,5,6,7,8,9,10,11,12;

IO=3E8h; IRQ=3,4,5,6,7,8,9,10,11,12;

IO=2E8h; IRQ=3,4,5,6,7,8,9,10,11,12;

4.2.4 Serial Port 3 Configuration

Advanced->IT8786E Super IO Configuration->Serial Port 1 Configuration

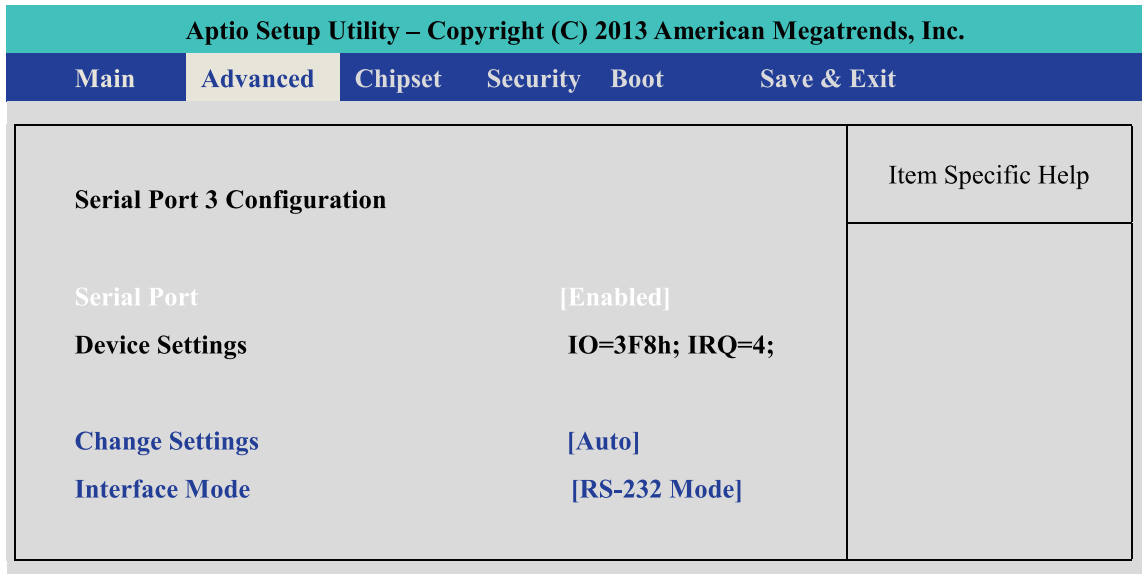

Figure 4.2.4: Serial Port 1 Setup screen

Serial Port :

Enable or Disable Serial port.

Device Setting:

Current IO addresses and interrupts resource of Serial Port.

Change Settings :

Select another device setting.

Here have 6 options :

Auto

IO=3F8h; IRQ=4;

IO=3F8h; IRQ=3,4,5,6,7,8,9,10,11,12;

IO=2F8h; IRQ=3,4,5,6,7,8,9,10,11,12;

IO=3E8h; IRQ=3,4,5,6,7,8,9,10,11,12;

IO=2E8h; IRQ=3,4,5,6,7,8,9,10,11,12;

Interface Modes :

Select UART transfer and receive protocol

Here have 3 options :

RS-232 Mode

RS-422 Mode

RS-485 Mode

4.2.5 Serial Port 4 Configuration

Advanced->IT8786E Super IO Configuration->Serial Port 1 Configuration

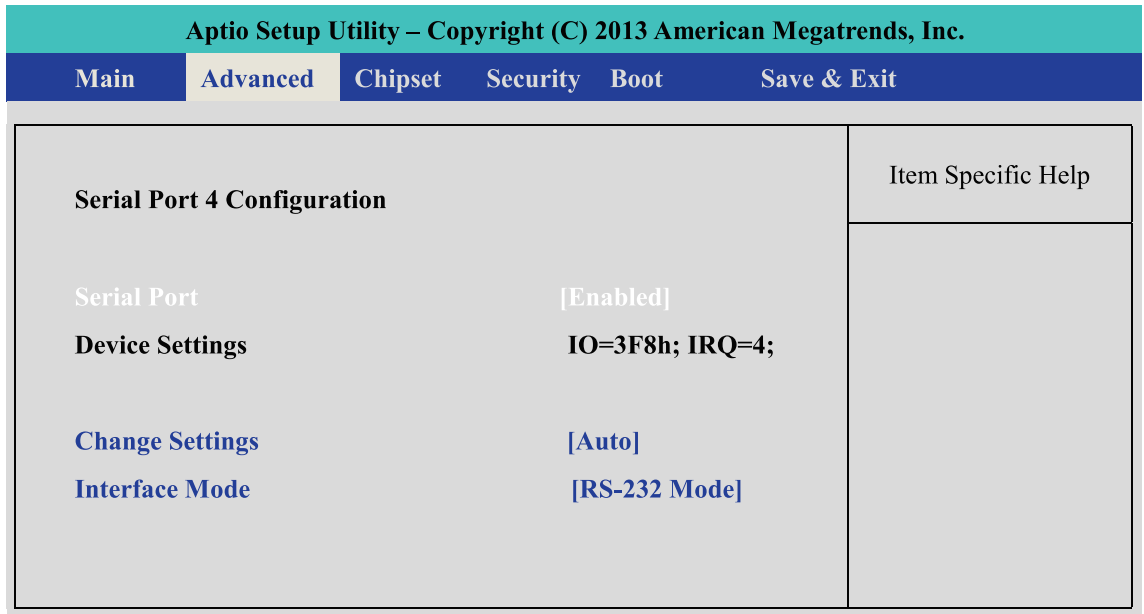

Figure 4.2.5: Serial Port 1 Setup screen

Serial Port :

Enable or Disable Serial port.

Device Setting:

Current IO addresses and interrupts resource of Serial Port.

Change Settings :

Select another device setting.

Here have 6 options :

Auto

IO=3F8h; IRQ=4;

IO=3F8h; IRQ=3,4,5,6,7,8,9,10,11,12;

IO=2F8h; IRQ=3,4,5,6,7,8,9,10,11,12;

IO=3E8h; IRQ=3,4,5,6,7,8,9,10,11,12;

IO=2E8h; IRQ=3,4,5,6,7,8,9,10,11,12;

Interface Modes :

Select UART transfer and receive protocol

Here have 3 options :

RS-232 Mode

RS-422 Mode

RS-485 Mode

4.2.6 Serial Port 5 Configuration

Advanced->IT8786E Super IO Configuration->Serial Port 1 Configuration

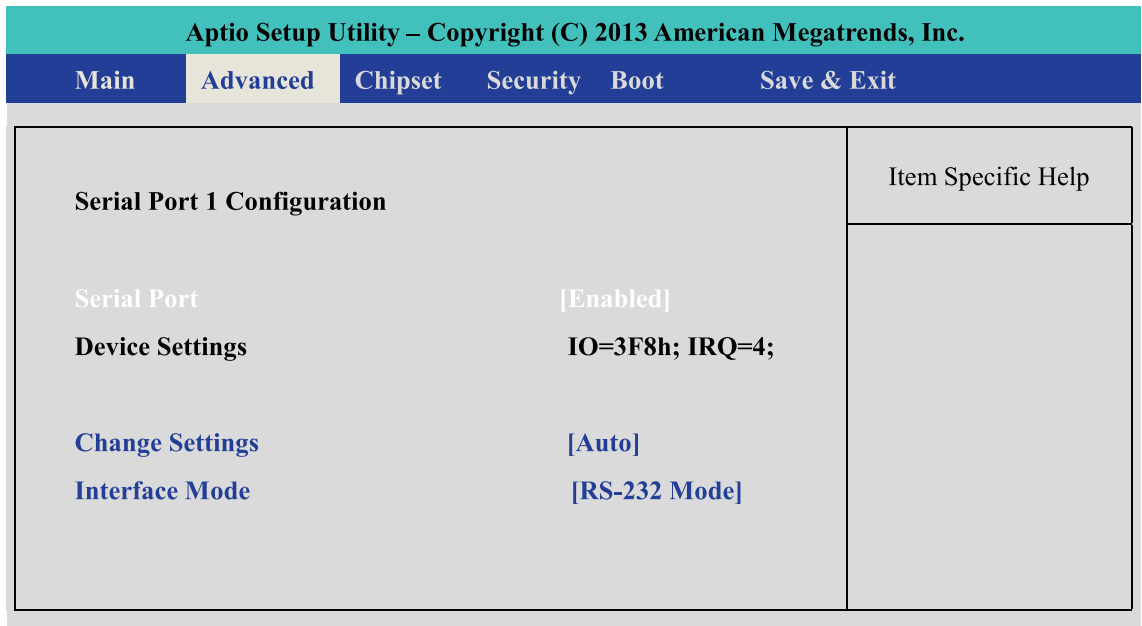

Figure 4.2.6: Serial Port 1 Setup screen

Serial Port :

Enable or Disable Serial port.

Device Setting:

Current IO addresses and interrupts resource of Serial Port.

Change Settings :

Select another device setting.

Here have 6 options :

Auto

IO=3F8h; IRQ=4;

IO=3F8h; IRQ=3,4,5,6,7,8,9,10,11,12;

IO=2F8h; IRQ=3,4,5,6,7,8,9,10,11,12;

IO=3E8h; IRQ=3,4,5,6,7,8,9,10,11,12;

IO=2E8h; IRQ=3,4,5,6,7,8,9,10,11,12;

Interface Modes :

Select UART transfer and receive protocol

Here have 3 options :

RS-232 Mode

RS-422 Mode

RS-485 Mode

4.2.7 Serial Port 6 Configuration

Advanced->IT8786E Super IO Configuration->Serial Port 1 Configuration

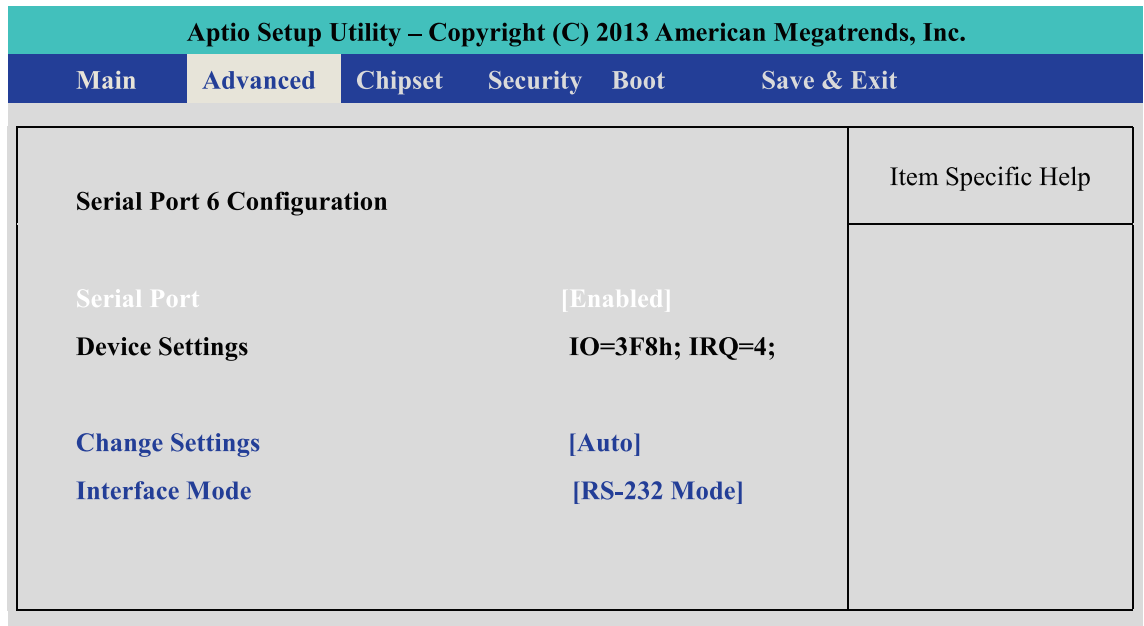

Figure 4.2.7: Serial Port 1 Setup screen

Serial Port :

Enable or Disable Serial port.

Device Setting:

Current IO addresses and interrupts resource of Serial Port.

Change Settings :

Select another device setting.

Here have 6 options :

Auto

IO=3F8h; IRQ=4;

IO=3F8h; IRQ=3,4,5,6,7,8,9,10,11,12;

IO=2F8h; IRQ=3,4,5,6,7,8,9,10,11,12;

IO=3E8h; IRQ=3,4,5,6,7,8,9,10,11,12;

IO=2E8h; IRQ=3,4,5,6,7,8,9,10,11,12;

Interface Modes :

Select UART transfer and receive protocol

Here have 3 options :

RS-232 Mode

RS-422 Mode

RS-485 Mode

4.2.8 PPM Configuration

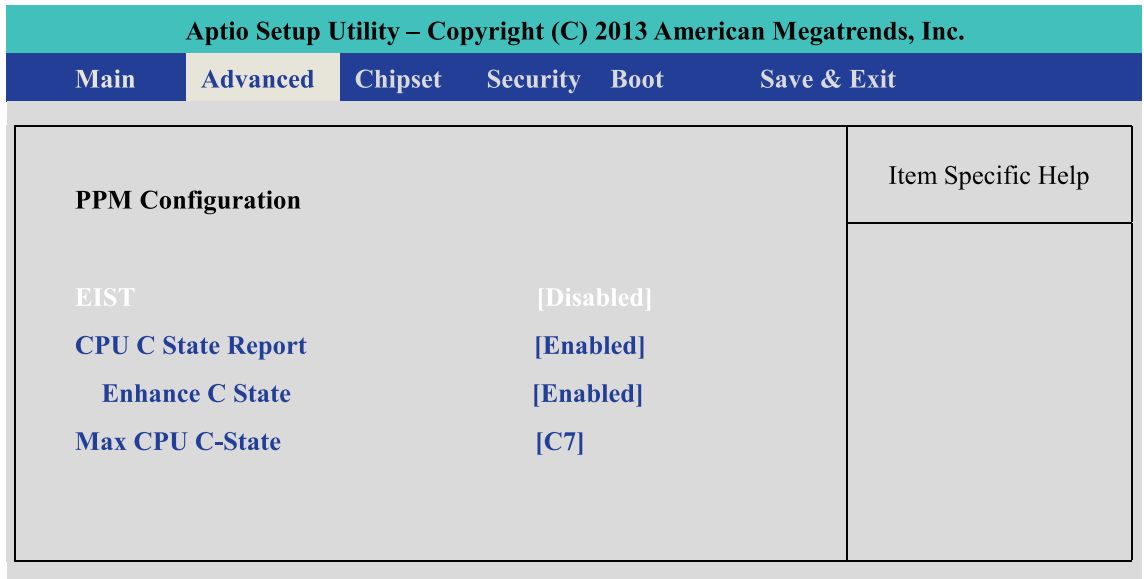

Figure 4.2.8: Trusted Computing setup screen

EIST :

Enables or Disables Intel Speed function , once you enabled it , you could use the Intel Turbo Boost software to monitor you CPU performance. Please refer to CPU check list.

4.2.9 CPU Configuration

Advanced->CPU Configuration->Socket 0 CPU Information

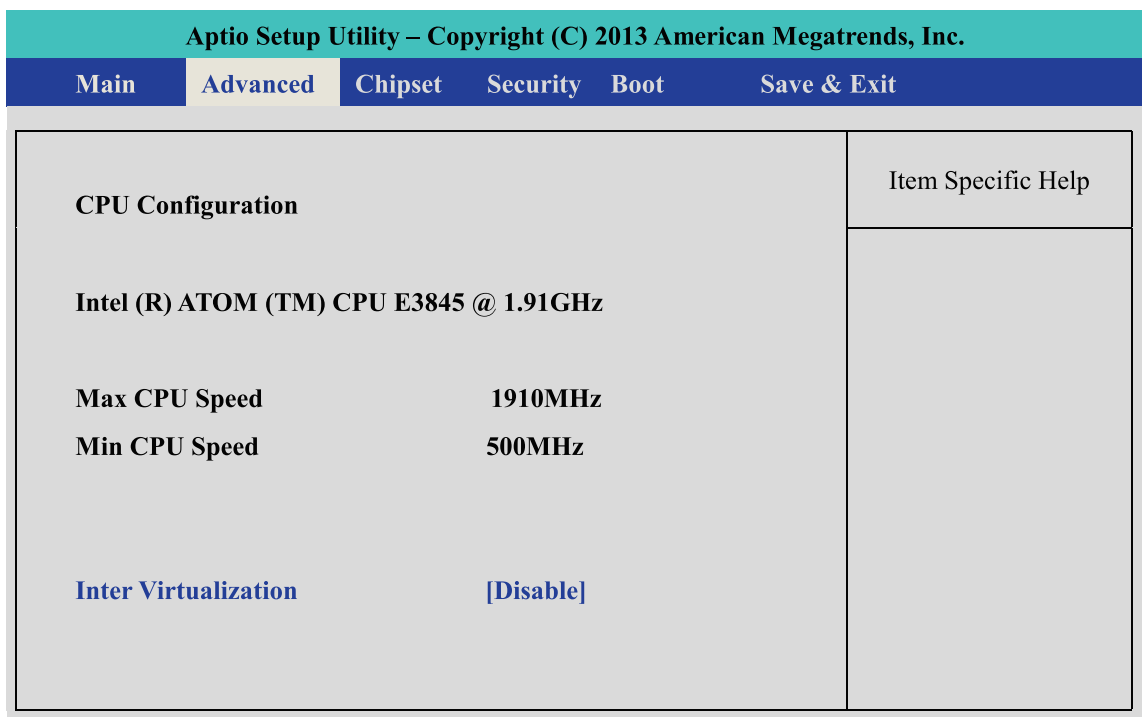

Figure 4.2.9: Trusted Computing setup screen

Intel® Virtualization Technology :

This is for Virtualization Application or platform usage, when enabled, a VMM can utilize the additional hardware capabilities provided by Vanderpool Technology,

4.2.10 IDE Configuration

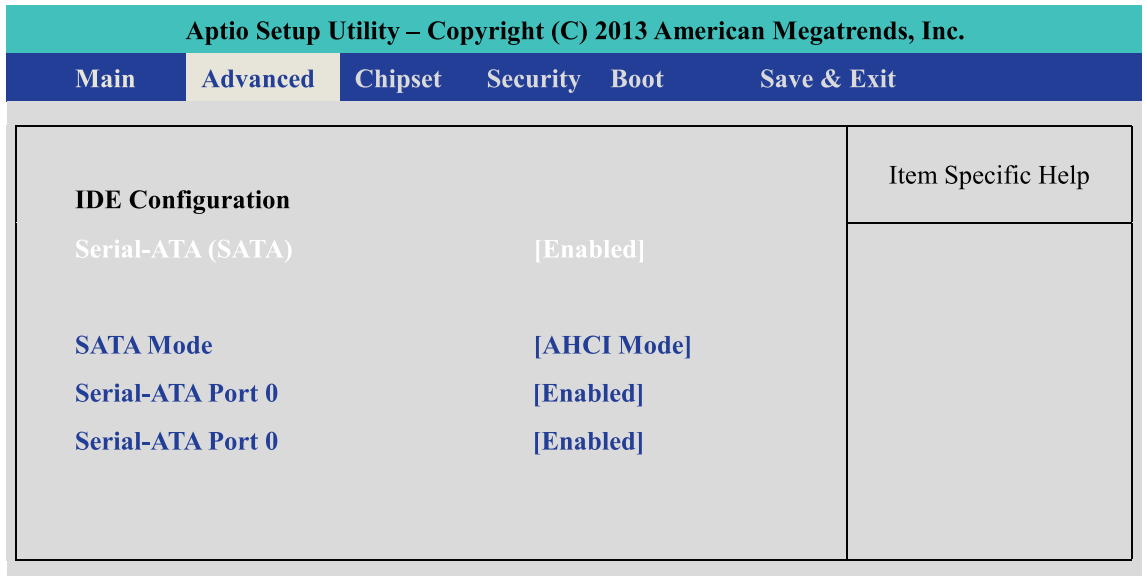

Figure 4.2.10: SATA Configuration setup screen

Serial-ATA(SATA) :

Enables or Disables integrate SATA controller for Storage device use.

SATA Mode Selection:

Determines how the SATA transfer mode for operate. Here have three option for choice [IDE] / [AHCI] .

Serial Port 0~1 :

This system offers two SATA port for connection SATA device.

4.3 Chipset Function



4.3.1 Display Configuration

Chipset->North Bridge->Intel IGD Configuration->Primary Display

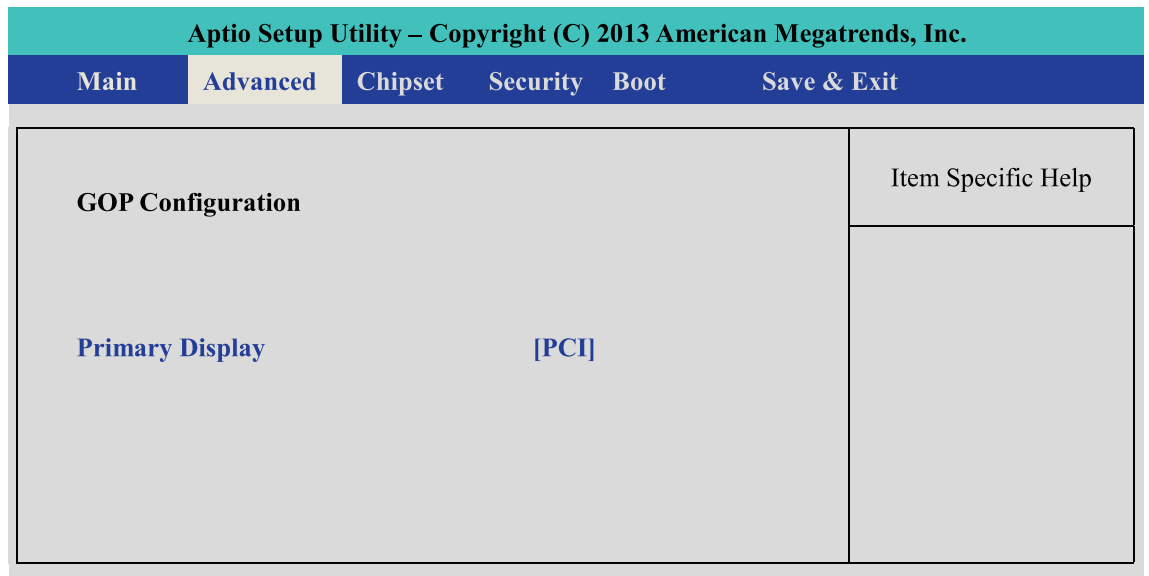

Figure 4.3.1: Network Setup screen

Primary Display:

Select which Display module you would like to you on current system.

[PCI] : System display function will be change to internal PCI or PCIe bus.

[IGD] : Use Internal Intel HD Graphics unit for unique display output.

4.3.2 Power Loss Configuration

Chipset->South Bridge

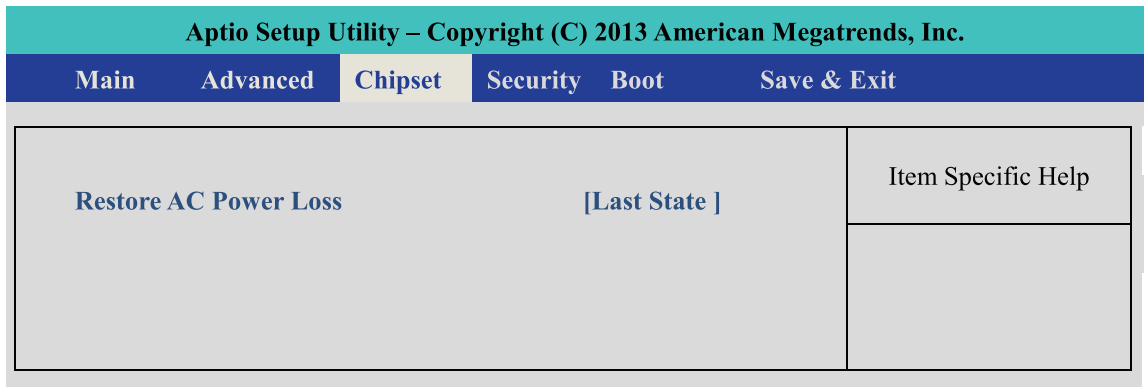

Figure 4.3.2: Power Loss Setup screen

Restore AC Power Loss :

[Power Off] : When plug-in the power source , system will keep on SB mode.

[Power On] : When plug-in the power source , system will auto booting .

[Last State] : When plug-in the power source , system will keep on last power status.

4.4 Boot Function



4.4.1 Change Boot Configuration

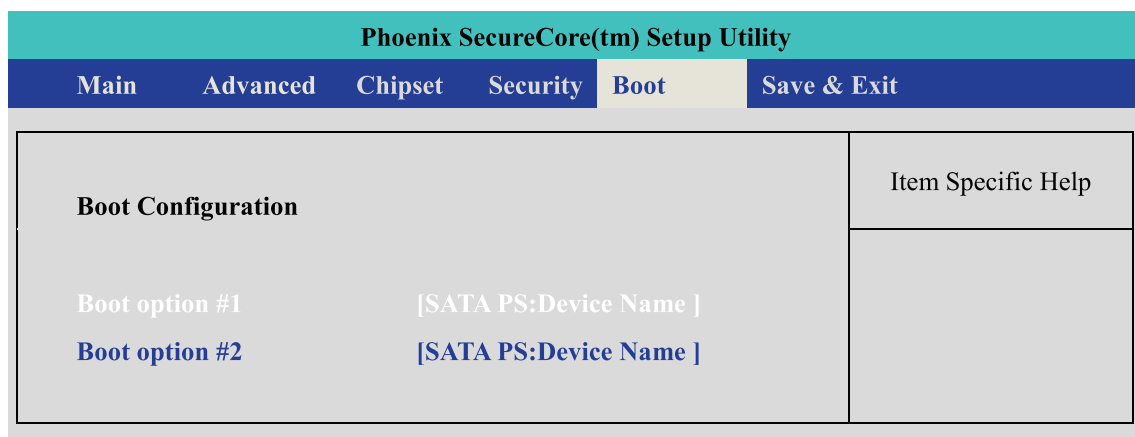

Figure 4.4.1: Boot Setup screen

Boot option:

When you press “Enter” , you can select which device you would like to boot.

4.5 Save & Exit



4.5.1 1.5.1. Reload Default BIOS Value

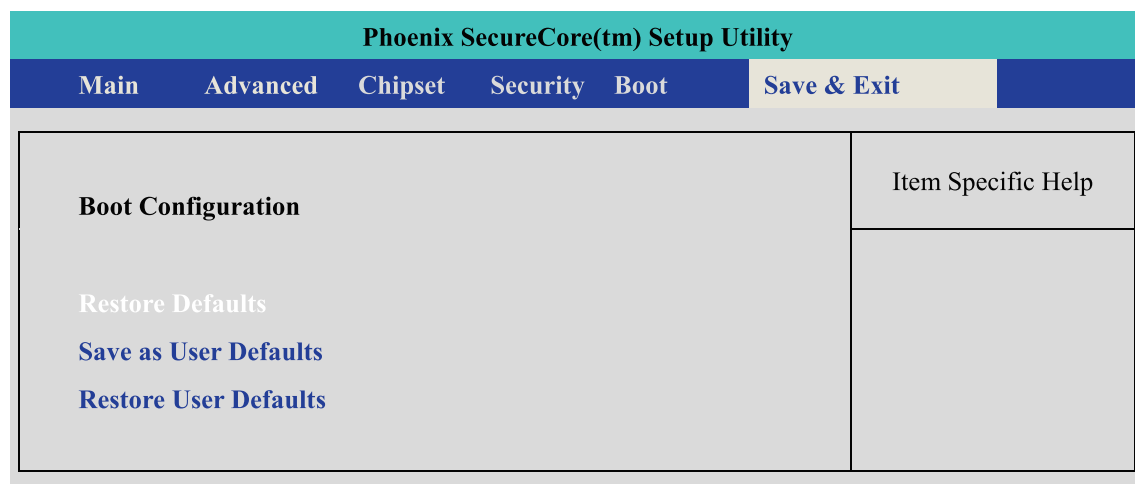

Figure 4.5.1: Boot Setup screen

Restore Default:

Use the function to restore all BIOS setting, but not include administrator password and system RTC value.

Save as Use Default:

Users can use this function to match the target system.

Restore as Use Default:

Restore all BIOS setting to User Default.

Appendix A : GPIO & WDT

■ Operation System Support

Linux :

Ubuntu 12.04 LTS or Above

Fedora 16 or Above

And another Linux kernel 2.6.38 and RHL6.0

(* The Linux kernel of RHL , please check RadHat website first)

Windows :

Windows 7 Home/Professional/MediaCenter/

Windows 8 (Do not support RT version)

Windows Server 2012

■ GPIO & WDT Function

The GPIO& WDT are using internal Super IO function. However, you must entry super I/O configuration mode to set it.

The output port is set as GPIO 1 on CN13 , reg. index = **0x60**

The input port is set as GPIO 4 on CN12 , reg. index = **0x62**.

Super I/O special address port = 0x2E

Super I/O special data port = 0x2F

GPIO Logical device is 0x07

Pin No.	SIO GPIO Function
1	SIO_GPIO77
2	SIO_GPIO76
3	SIO_GPIO75
4	SIO_GPIO74
5	SIO_GPIO73
6	SIO_GPIO72
7	SIO_GPIO71
8	SIO_GPIO70
9	GND

■ A.Entry MB PnP mode.

//write twice 0x87 value.

```
outportb(Super I/O special address port, 0x87);
outportb(Super I/O special address port, 0x01);
outportb(Super I/O special address port, 0x55);
outportb(Super I/O special address port, 0x55);
```

■ B.Located on Logical Device 7

//write 0x07 on Reg [0x07] , this setup must follow Step A. that can be workable.

```
outportb(Super I/O special address port, 0x07);
outportb(Super I/O special data port, 0x07);
```

■ C.Access the Super I/O register

Base control for write Super I/O register.

```
outportb(Super I/O special address port, Register Index.);
outportb(Super I/O special data port, update_value);
```

Base control for read Super I/O register

```
outportb(Super I/O special address port, Register Index.);
inportb(Super I/O special data port); //It will return a
BYTE value.
```

■ D.Start to Access the ABP-2000 series GPIO port

Please refer to source code for set_data() and get_data() function.

Write data to GPO(output) port

```
set_data( Register Index , update_value);
```

example :

```
unsigned char data = 0x82;
```

```
set_data( 0xE5 , data);
```

```
//Set bit 7 & bit 1 of GPO output port as High level
,another bit is Low
```

Read data to GPI(input) port

```
get_data( Register Index ) //It will return a BYTE value.
```

example :

```
unsigned char data
```

```
get_data( 0xF1 , data);
```

```
//Get GPI(input) port status on input_data variable.
```

■ E.WDT ON/OFF and Timer-Counter setting

Refer to GPIO setting of Step A and B. , located Logical

0x08 for WDT function.

Reg [0x72] is WatchDog ON/OFF control.

WatchDog On : set_data(0x30 , 0x01);

WatchDog Off : set_data(0x30 , 0x00);

Reg [0x73] is WatchDog timer – For WDT Timer out value

WatchDog counter start : set_data(0xF0 , 0x02);

WatchDog counter start : set_data(0xF0 , 0x00);

Reg [0x72] is WatchDog time-out value, “**Reading**” this register returns the current value in the Watch Dog Counter, not the Watch Dog Timer Time-out value..

WatchDog time-out value: set_data(0xF1 ,);